

d i g i t a l

Level of Urgency
FCO RA81X-I-013

Page _____
Of _____

FIELD CHANGE ORDER

Number: RA81X-I-013

APPLICABILITY: If your HDA is marked H1 or above, or has a serial number of CX 49250 or above, or KB 6539 or above, THAT HDA IS GOOD AND DOES NOT NEED REPLACEMENT.

RA81 HDAs which are revisions below H1 or which have serial numbers below CX 49250 or KB 6539 are subject to this FCO. There are only two exceptions to this rule. There are 3141 HDAs between serial numbers CX 49250 and 52390 which are free of the adhesive defect, but which were not marked "H1". They were marked "F1". These HDAs are NOT subject to the FCO. There are 1161 HDAs between serial numbers KB 6539 and 7700 which are free from the adhesive defect, but are marked "E1". These HDAs are NOT subject to the FCO either.

Please note that as HDAs are repaired and the adhesive defect removed, the rev of the HDA is bumped to the most current rev, at least H1 presently. The serial number NEVER CHANGES!! Therefore it is possible to have a serial number like CX 2000 which is rev H1, and therefore a GOOD HDA!!

Problem/Symptom: The adhesive used to attach the gaskets to the spindle air filter assembly breaks down at the upper end of the drive operating specification. This causes head to disk interference to occur.

Quick Check: HDA revision level "H1" or with a serial number above CX49250 or KB6539 will have the adhesive removed from the air filter assembly and therefore be a "GOOD" HDA

Compatibility/Prerequisite FCO:
RA81X-R-0009, RA81X-R-012 and RA81X-I-014

Est. Time to Install:
4.0 HOURS WORST CASE
2.5 HOURS BEST CASE

Special Tools or Test Equipment:
VELOSTAT KIT P/N 29-11762-00

PRELIMINARY

SUBJECT TO CHANGE WITHOUT NOTICE

RA81X-I-013 FCO COVER SHEET INFORMATION - CONTINUED

FCO Parts Information			
Order by FCO Kit#:	Quantity:	Part Number:	Description:
EO-01373-01	1	70-18491-01	16 BIT RA81 HEAD DISK ASSEMBLY
EO-01373-02	1	70-18491-02	18 BIT RA81 HEAD DISK ASSEMBLY
FA-04656-01	1		RA81X-I-013 FCO DOCUMENTATION
EQ-01275-01	1	10-13466-22	0.1 MFD 50V CAPACITOR
	1	13-05121-00	38.3 OHM RESISTOR, 1/4 WATT, 1%
FA-04544-01	1		RA81X-R-009 FCO DOCUMENTATION
FA-04649-01	1		RA81X-R-012 FCO DOCUMENTATION
EQ-01380-01	1	12-25629-01	GROUNDING STRAP
	3	90-08151-00	WASHER, EXT TOOTH
	4	90-10075-01	SCREW, TAP HEXWW
	3	90-06565-00	NUT, HEX EXT TOOTH LCKWSHR 10-32
	3	90-07651-00	WASHER, LOCK
FA-04662-01	1		FCO DOCUMENTATION

EQ Kit Variation System/Option Applic: THERE ARE SEPERATE EO KITS FOR LCG SYSTEMS' RA81s.
 PLEASE NOTE - IF YOU ORDER EQ-01373-01/02, YOU WILL RECEIVE ALL THE OTHER EQ KITS LISTED ABOVE. IF YOU SHOULD NEED ADDITIONAL KITS, THEY WILL NEED TO BE ORDERED SEPERATELY.

Approvals

CSSE Engineer KEITH BROWN	F.S. Product Safety	F.S. Logistics
CSSE Manager RON MILANO	F.S. Microfiche Libraries	Affected Population:
ESD&P Micropub.		Initial Kitting:
Revision:		Hardcopy Publication:
FCO Release Date		Parts Availability:

HDA REPLACEMENT FCO

 *
 * *** NOTE *** *
 *
 * HDA'S SHOULD BE HANDLED WITH CARE AT ALL TIMES. DAMAGE *
 * WILL OCCUR FROM IMPROPER HANDLING. RETURNED HDA'S WILL *
 * BE REFURBISHED AND REISSUED FOR FIELD REPAIRS. *
 *

PRELIMINARY

SUBJECT TO

* N O T E *
*

* A period of time should be allowed for temperature
* stabilization to occur when transporting HDA's from colder
* to warmer environments, or vice versa. The possibility for
* condensation to form when the HDA has been cooled then
* heated quickly, is quite high. This causes head disk
* interference (HDI) to occur. The LED codes that can be
* expected are as follows.
*

SERVO	HEAD/MEDIA
25 4B 4D F8 F9	51 52 53 62 63 65 66

* Arrangements should be made with the customer to insure
* that the HDA has time to stabilize. There is a requirement
* for a period of thermal stabilization of HDAs before they
* are spun up in drives. During the winter months, when a
* large portion of this FCO activity will take place in the
* Northern Hemisphere, the difference in temperature between
* an HDA that has just come in from being transported in the
* cold, and a computer room environment can be quite large.
* If no time is allotted for this temperature difference to
* equalize, humidity in the air inside the HDA can actually
* condense into water inside the HDA and the probability of a
* head crash is high. The time required for stabilization
* varies directly with the difference in temperatures.
*

* In storage or shipping, (with the HDA packaged for shipping)
* the HDA should not be subjected to temperatures outside the
* range specified by DEC Standard 102, -40C (-40F) to 66C
* (151F). The maximum temperature gradient must not exceed 22
* deg C per hour, or 40 def F per hour. If the ambient
* temperature in which the HDA was stored was between 10C and
* 38C (50F and 100F), the HDA may be installed immediately.
* If the ambient temperature was between 0 deg C and 10C,
* (30F and 49F) the HDA should be allowed to warm to room
* temperature 22C, (appox. 70F) in the closed shipping
* container for three hours minimum and then installed. For
* temperatures below 0 deg C, (30F), allow 1 1/2 hours more
* for every 12 C (10 deg F) in addition to the three hour
* minimum.
*

* A very cold HDA that was stored in a van overnight at -23 C,
* (-10 deg F) for example, could take as much as 9 hours to
* thermally stabilize to the point where actual operation
* would not be risky. A maximum period of 13.5 hours could be
* required to allow thermal stabilization to take place from
* the lowest acceptable temperature to a standard computer
* room temperature.
*

* With this in mind, it may be appropriate to have HDAs
* delivered to the site which is to be FCO'd the day or
* evening before the acutal FCO installation is to take place.
*

PRELIMINARY

SUBJECT TO CHANGE WITHOUT NOTICE

 * HDA HANDLING INFORMATION *
 *
 * A LARGE NUMBER OF THE HDA'S THAT ARE RETURNED FROM THE FIELD *
 * HAVE PROBLEMS THAT CAN BE AVOIDED IF THE FOLLOWING RULES ARE *
 * OBSERVED. *
 *
 * 1) WHEN INSTALLING/DE-INSTALLING HDA'S THE HEADS/POSITIONER *
 * SHOULD ALWAYS BE IN THE "LOCKED" POSITION. *
 * 2) THE HEAD/POSITIONER SHOULD ALWAYS BE LOCKED PRIOR TO THE *
 * DRIVE BEING MOVED. *
 * 3) THE HDA SPINDLE/PULLEY SHAFT SHOULD NEVER BE SPUN BY *
 * HAND IN EITHER DIRECTION. *
 * 4) THE RUBBER SPINDLE/PULLEY SHAFT LOCK SHOULD BE INSTALLED *
 * WHEN RETURNING HDA'S FOR REPAIR. THIS LOCK IS BEING *
 * SHIPPED WITH ALL FIELD REPLACEMENT HDA'S. *
 * 5) WHEN REMOVING HDA'S FROM THE DRIVE, THE HDA SHOULD *
 * ALWAYS BE PLACED UPRIGHT ON THE PLASTIC BULKHEAD FEET *
 * END. IT SHOULD NEVER BE PLACED ON THE SPINDLE/PULLEY *
 * SHAFT. *
 * 6) WHEN CLOSING THE LOGIC CHASSIS ASSEMBLY THE HDA/DRIVE *
 * SHOULD BE SPUN DOWN PRIOR TO CLOSING. WHEN THIS CHASSIS *
 * DOES NOT CLOSE PROPERLY, THE LATCH SHOULD BE ADJUSTED. *
 * THE CHASSIS SHOULD NOT NEED TO BE SLAMMED SHUT. *
 * 7) WHEN INSTALLING THE DRIVE, ALL HDA SHIPPING BRACKETS *
 * SHOULD BE REMOVED, AND HDA HOLD DOWN NUTS SHOULD BE *
 * REPLACED. THESE NUTS SHOULD BE VERY FIRMLY TIGHTENED *
 * BUT ONLY FINGER TIGHT. DO NOT OVER TIGHTEN THE NUTS, *
 * THIS WILL CAUSE THE SHOCK MOUNTS TO BECOME INEFFECTIVE. *
 * 8) ESD PROTECTION SHOULD ALWAYS BE OBSERVED WHEN HANDLING *
 * HDA'S. *
 * 9) ALWAYS USE THE RUN/STOP SWITCH TO SPIN THE DRIVE DOWN. *
 * !!NEVER!! USE THE DRIVE CIRCUIT BREAKER TO STOP THE *
 * DRIVE. *
 * 10) ALWAYS USE THE HDA SHIPPING CONTAINER FOR TRANSPORTATION *
 * OF HDA'S TO AND FROM THE SITE. IT IS DESIGNED TO *
 * PROTECT THE HDA FROM BEING DAMAGED DUE TO MISHANDLING. *
 * HDA'S SHOULD REMAIN IN THE BOX UNTIL REMOVED FOR THEIR *
 * ACTUAL INSTALLATION INTO THE DRIVE. !!NEVER!! TRANSPORT *
 * AN HDA ON ANY KIND OF WHEELED CART WITHOUT THE HDA BEING *
 * IN ITS BOX !!! *

 * *** NOTE *** *
 *
 * THE PREREQUISITE TO THIS FCO IS THE INSTALLATION OF FCO'S *
 * RA81X-R-009, RA81X-R-0012 AND RA81X-I-014 (SEE FCO QUICK *
 * CHECK'S BELOW). IF INSTALLATION OF THESE FCO'S ARE *
 * NECESSARY BUT ARE NOT ALREADY INSTALLED, IT IS RECOMMENDED *
 * THAT THEY BE INSTALLED BEFORE INSTALLING A NEW HDA. *

PRELIMINARY

SUBJECT TO CHANGE WITHOUT NOTICE

QUICK CHECK FOR RA81X-F-009

(SEE ATTACHED RA81X-R-009 FOR COMPLETE FCO OVERVIEW AND INSTRUCTIONS).

PRESENCE OF 0.1 UFD CAPACITOR AT LOCATION C29 AND 38.3 OHM PRECISION RESISTOR (ORANGE-GRAY-ORANGE) AT LOCATION R64. RA81X-S-004, R/W MODULE (54-15253) MUST BE AT CS REVISION LEVEL "D" BEFORE INSTALLATION OF THIS FCO. PROBLEM - HIGH RATE OF ERROR CODES 62 AND/OR 63. INTERMITTENT, UNEXPLAINED BURSTS OF ECC ERRORS.

QUICK CHECK FOR RA81X-R-012

(SEE ATTACHED RA81X-R-012 FOR COMPLETE FCO OVERVIEW AND INSTRUCTIONS)

MICROPROCESSOR DATA SEPARATOR WINDOW ADJUSTMENT

THE JUMPERS ARE LOCATED BETWEEN E169 AND E170 NEXT TO J304 READ/WRITE CABLE CONNECTOR.

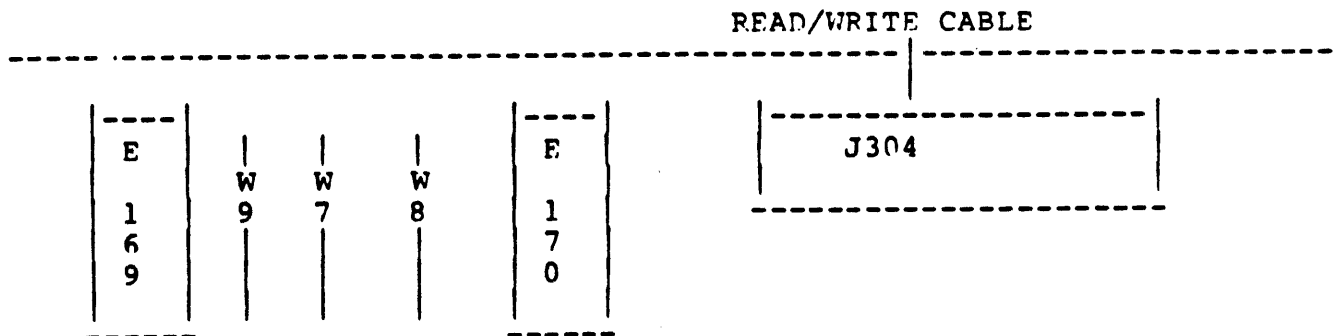

!!!THE FOLLOWING SETTINGS ARE THE ONLY ADJUSTMENTS THAT CAN BE MADE.!!!
IF ANY OTHER ADJUSTMENTS ARE PERFORMED THE DATA SEPARATOR WINDOW WILL BE OUT OF TOLERANCE.!!!

OLD SETTING	CHANGE	RESULT
W9, W8, W7 OUT	ADD W9	W9 IN
W9 IN W7, W8 OUT	ADD W8	W8 W9 IN
W8 IN W7, W9	ADD W7 AND W9 REMOVE W8	W7 W9 IN
W9 AND W8 IN W7 OUT	ADD W7 REMOVE W8	W7 W9 IN

* MICROPROCESSOR MODULES WITH AN ETCH "B", C.S. "K1" OR ETCH "C1", C.S. "M1" *
* REVISIONS SHOULD NOT BE ADJUSTED. RA81'S AT HARDWARE REVISION 6 WILL HAVE *
* THE "M1" OR THE "H2" MICROPROCESSOR. *

QUICK CHECK FOR RA81X-I-014

(SEE FCO RA81X-I-014 FOR COMPLETE FCO OVERVIEW AND INSTRUCTIONS).

HDA CHASSIS AND DRIVE CHASSIS ARE AT DIFFERENT GROUND REFERENCE.
DATA ERRORS (ECC) AND OTHER MISC. ERRORS NOT RELATED TO MEDIA DEFECTS.

SUBJECT TO CHANGE WITHOUT NOTICE

HDA REMOVAL PROCEDURE

- 1. Request the RA81 drive from the customer.

* A COMPLETE BACKUP MUST BE PERFORMED BEFORE STARTING *
* THIS PROCESS. A LOG AND VERIFY OPERATION SHOULD BE *
* USED DURING THE BACKUP/RESTORE PROCESS. *

RA81 VAXCLUSTER BACKUP NOTES

Before replacing an RA81 HDA, proper media backup MUST be done, preferably by the site system manager. CX-CSSE recommends using the VMS Backup utility for maximum data integrity.

Although the VMS Backup utility and procedures (to tape) are considerably slower than the HSC50 BACKUP and RESTORE utilities, potentially fewer tapes are used in VMS Backups, and write verifications are done if the /VERIFY qualifier is used with the VMS BACKUP command.

When invoking the VMS BACKUP utility, be sure that your customer uses the /REWIND and /VERIFY qualifiers to assure data integrity. BACKUP generated tape volume headers may become corrupted and render the remainder of the data on that tape volume inaccessible if those 2 qualifiers are not used. This is due to a VMS V4.0, VMS V4.1 and VMS V4.2 tape class driver bug.

The recommended command string for VMS Backup is;

\$Backup/Image/Verify/Rewind 'source_disk:' 'target_device:'

The Backup utility should be run from a hardcopy terminal, and all output messages from this backup should be preserved and reviewed by the field engineer installing the RA81 HDA FCO and the site system manager. Any abnormal BACKUP messages ie. %BACKUP-E-BADDATA OR -FORCEDERROR should be flagged and any questions regarding the messages and recovery actions should be routed by the field service engineer to the respective support groups OR TSC.

For optimum speed, an HSC50 Backup will utilize 4 2400 foot reels of tape to completely backup an entire RA81 drive. The HSC50 BACKUP utility does a physical backup of a RA series disk and has no knowledge of any type of operating system file structures on a disk. The HSC50 Backup utility uses the tape functionality of read after write, but does not do complete rewind and read verification.

7-11-83
SUBJECT TO CHANGE WITHOUT NOTICE

ULTRIX BACKUP NOTES

The best possible way to back up the file systems on RA81's is to do a zero level dump of each file system on the RA81.

THIS SHOULD BE DONE AT THE SINGLE USER LEVEL.

There is no verify pass under the dump program. Due to tape errors it maybe wise to dump each file system tape twice...But that should be up to the customer. After the HDA is replaced the customer will have to make new file systems on the RA81. Details of the "backup" process are available in the software notebooks.

Additional information, or specific instructions, can be provided by the ULTRIX Customer Support personnel at the Customer Support Center.

RSTS/E BACKUP NOTES

For the customer that has multiple RA81's, using the SAVRES program to do an IMAGE copy from one RA81 to another would be the fastest and most effective method. If only using a Mag Tape drive in the backup, SAVRES can be used also. Doing an image SAVE to "tape" can be accomplished, however, in all cases the /VERIFY switch should be used and possibly a second SAVSET for safety sake.

RSTS development feels that SAVRES is easiest, especially for V7.2 and V8.0. They also suggest that 2 backups are better than one.

When possible a BACKUP of the customer data should ALSO be done. V7.2 and V8.0 use the 'old' RSTS backup. V9.0's new backup is easier and more reliable than the 'old'. This backup can be used to selectively restore customer files should the need arise. Save sets cannot be restored selectively.

Since the "new" version 9.X backup is not widely known, the customer should reference the software documentation, if not familiar with it.

SAVRES also has the ability to "halt" on the occurrence of an error during the "copy" of the data. If you wish to have SAVRES halt on the occurrence of an error, the /NOERROR switch can also be used. This way any error can be examined on its occurrence and the "backup" terminate. The error may have to be "repaired" before restarting the SAVRES "backup".

It would also be recommended that customers, "clean-out" any files that are no longer needed, before starting the SAVRES. This way any files that will no longer be needed, can be deleted and not add to the time that SAVRES runs.

Details of the SAVRES, and BACKUP, commands are in the RSTS/E System Managers Guide. Any additional information needed or help in the process can be directed to the customers local DEC Software Support Specialist, or if necessary the Customer Support Center RSTS/E Customer Support Personnel.

CONFIDENTIAL

RSX11M (+) BACKUP NOTES

DISK TO TAPE

We recommend using online BRU (M-PLUS V2.1 Update E or later/11M V4.1 update E or later) if that is possible. If it is not possible, because the disk to be backed up is the system disk, (i.e. the disk that the system was booted from), standalone BRU (BRUSYS or BRU64K) from the M-PLUS V3.0/11M V4.2 distribution should be used.

UNDER NO CIRCUMSTANCES SHOULD B:U /IMAGE (FROM ANY DISTRIBUTION) BE USED!!!!

The recommended procedure for backing up and restoring an entire disk to tape is:

- 1) For online BRU
 - >MOU mmn:/FOR ; mount the tape foreign
 - >MOU ddn:/FOR ; mount the disk foreign (to insure exclusive
; access)
 - >BRU /VER ddn: mmn: ; backup with verify (each tape will be
; verified immediately after it is written)

After the HDA is replaced:

- >BAD ddn: ; run BAD on the NEW disk
- >BRU /VER/INI mmn: ddn: ; restore with verify (the entire disk
; will be restored before the verifv
; pass)

PLANNED
REVISIONS

SUBJECT TO CHANGE WITHOUT NOTICE

CONTINUED RSX11M (+) BACKUP NOTES

- 2) For standalone BRU, boot up BRU64K (on 11M) or BRUSYS (on M-PLUS) then you will be prompted for the devices you are going to use (see p7-23 of the Utilities Manual). You can enter /DEV at this point to see if the vectors and CSR's are correct for the devices you wish to use (they are correct if the device shows online, they are incorrect if the device says offline). You can enter the correct vector and CSR at this point - the example below shows this.

Enter first device: DU0:/CSR=172150/VEC=154

Enter second device: mmn:

>RUN BRU

BRU>/VER ddn: mmn: ; backup with verify (each tape will be
; verified immediately after it is written)

After the disk is replaced, you will have to reboot BPU as before,
and answer the device questions as before. Then

>RUN BAD ; run BAD on the new disk

BAD>ddn:

>RUN BRU

BRU>/VER mmn: ddn: ; restore with verify (the entire disk will
; be restored before the verify pass)

Note: Backing up a "full" RA81 to tape at 1600 BPI may require
between 13 and 15 2400 ft. tapes. For the purpose of HDA
replacement, the tapes used should be the best quality you can
find (AT LEAST certified to 6250 BPI)

NOTE

11M V4.2 and M+ V3.0 have not yet gone to the SDC. So for
those systems where they must use standalone BRU, A copy
of standalone BRU will need to be obtained.
(if it hasn't shipped by then, or if the customer is not under
contract).

If the customer isn't running a recent version of RSX,
It will be difficult to advise what to do.

PRELIMINARY

SUBJECT TO CHANGE WITHOUT NOTICE

DISK TO DISK COPIES

- if the customer has a tape drive - use the tape method
- if they have another RA81, they can use the same method we recommend for tape - just substitute the second disk name for the tape unit
- if they have other disks that are big enough to hold the data from the RA81 assuming it's not full, they can use BRU to copy the data to that other disk -
- the biggest problem with disk to disk copies, is that the /IMAGE mode of BRU which is used to copy a big disk to multiple little disks in BRU format doesn't always work - and you don't know it didn't until you try to restore - a problem we definitely want to avoid.

DSM-11 (MUMPS) BACKUP NOTES

The DSM-11 BACKUP utility is the best way to go. DSM-11's BACKUP utility DOES NOT have a verify option!

It might be wise to do the BACKUP and then do a RESTORE to make sure the BACKUP worked. In this case the BACKUP would have to be done to some other media or a "scratch" RA81, in order to preserve the "master" copy being backed-up, until it can be "verified" that the backup copy is good.

DSM-11 just finished field test, so a new release, V3.1 may well be in the field by the time you start doing any of this. I will mention that 3.0A BACKUP had problems and BACKUP has been rewritten for the new release.

Specific instructions for the use of the BACKUP utility is in the software manuals. Any additional information on the use of this utility can be directed to the appropriate DSM-11 Customer Support Personnel.

IAS BACKUP NOTES

Since IAS is a "type" of RSX, many of the RSX concepts need to be understood. IAS has a backup utility like the RSX "BRU" that can be used.

IAS engineering has suggested that the best way to go is to use BRU with verify enabled. Then re-run BRU with the compare qualifier.

PRELIMINARY

SUBJECT TO CHANGE WITHOUT NOTICE

The best way to proceed is as follows:

- 1) Run the DLUSER utility to preserve ALL the directory information on a structure. The file containing this information should probably be put in a secure environment such as <OPERATOR> rather than <F-S>. Also, the DLUSER data should be kept in machine readable form and (as silly as it sounds) make sure the DLUSER data does NOT go on the HDA or structure about to be replaced.
- 2) use DUMPER to do a FULL save of the entire structure. One should probably do this on a 6250 BPI Tape drive (@6250 BPI) at some relatively high blocking factor such as 8 or 10. TU72s or TU78s are probably the best way to do this.
- 3) REWIND the DUMPER tape.
- 4) Run the CHECK DUMPER function to verify the data that you've backed up.

Obviously, there should be no users of the structure at the time of the full save. Also, it might be a good idea to run the tape drive reliability diagnostic to be on the safe side.

Once the FCO is complete:

-
- 1) run CHECKD to rebuild the structure.
 - 2) use DLUSER to replace all the directories on the structure
 - 3) then do a full restore on the structure using the DUMPER tapes you earlier produced/verified.

The DLUSER steps are probably critical because DUMPER does not preserve all directory attributes in some versions in the field.

This is all covered in one of the following three places - the OPERATOR's guide (vol 10 of the SW notebooks), the System Manager's Guide (vol 9) and the KL Model B Installation guide (also vol 9).

You should also be aware that a structure under TOPS-20 can span up to 4 RA81 spindles. This means that once one spindle/pack is replaced, the ENTIRE structure must be rebuilt. Said another way, to replace one HDA, the entire volume-set must be backed up and reconstructed.

Tight cooperation between the engineer replacing the HDA and the systems programmer/manager is encouraged.

- CONTINUATION OF FCO PROCESS -

2. The RA81 drive must be dismounted and deselected.
3. Depress the "A and B" port switches on the Operator Control Panel to the "OUT" position. See Figure 1.

PRELIMINARY

SUBJECT TO CHANGE WITHOUT NOTICE

HDA INSTALLATION PROCEDURE

REMOVED COPY
SUBJECT TO...

1. Remove the new HDA from the shipping container and place it gently on a flat work surface. HDA's should always be placed on the work surface with the plastic bulkhead feet facing down. (Figure 9)
2. Remove the plastic spindle/pulley lock from the spindle shaft of the new HDA. (Figure 10)
3. Attach the spindle/pulley lock to the old HDA spindle shaft. (Figure 10)
4. Install the new HDA into the lower chassis.
5. Reattach the four (4) HDA hold down nuts to the shock mounts. The nuts should be quite firm and snug, but only be FINGER TIGHTENED. (Figure 8)

* NOTE *
* THE INSTALLATION OF FCO RA81X-I-014 SHOULD BE PERFORMED AT *
* THIS TIME. ALSO VERIFY THAT FCO RA81X-R-009 HAS BEEN *
* INSTALLED. IF IT IS NOT INSTALLED, DO SO AT THIS TIME. *

6. Once FCO RA81X-R-009 and RA81X-I-014 have been completed, then reattach the Read/Write module using the four (4) hold down screws
7. Reconnect cables P501, and P502 to the Read/Write module. (Figure 8)
8. Reconnect cables P601, P602 and P603 to the bulkhead cover. (Figure 8)
9. Place the belt tension lever in the engaged position. (Figure 8)
10. Place the positioner lock arm in the unlocked position and remove the E.S.D. wrist strap from the ground stud. (Figure 8)
11. Close, but DO NOT SLAM the logic chassis.

NOTE
AT THIS TIME, VERIFY THAT THE INSTALLATION OF FCO RA81X-R-012 HAS BEEN PERFORMED. IF NOT INSTALLED, PERFORM THIS FCO AT THIS TIME.

12. If this is a fixed mount drive, proceed to step 15.
13. Push in on slide arm "B" and slowly slide the Drive back into the cabinet. (Figure 5)
14. Reinstall the screw holding the back of the Drive to the electrostatic discharge bracket. (Figure 4)

 * C A U T I O N *
 * *
 * The screw holding the back of the Drive to the *
 * electrostatic discharge bracket must be installed. *
 * *

15. Reconnect the AC power cord, at the rear of drive, to the AC receptacle. (Figure 2)
16. Turn the AC Circuit Breaker, at the rear of the drive, to the "ON" position. (Figure 2)
17. Spin up the Drive by pressing the RUN/STOP switch. (Figure 1)
18. After the Drive has spun up and a ready light is "ON", press the "A" and/or "B" port switches on the Operator Control Panel to the "IN" position. (Figure 1)
19. Run the appropriate RA81 drive diagnostics for at least 30 minutes.

VAX	32 BIT	UDA50, EVRLA or EVRLG HSC50/ILEXER
PDP-11	16 BIT	UDA50, CZUDC or CZUDI
DEC 10/20	36 BIT	HSC50/ILEXER

20. Return the RA81 drive to the customer for software restore/initialization.
21. Enter all FCO activity in the Site Management Guide.
22. Complete the LARS form as shown in APPENDIX A.
23. Lock the Head/Positioner and re-install the spindle locking strap onto the old HDA (Figure 10). Fill out the attached form (Appendix B) and carefully place the old HDA, along with this form, in the shipping container and return it to your Logistics Department.

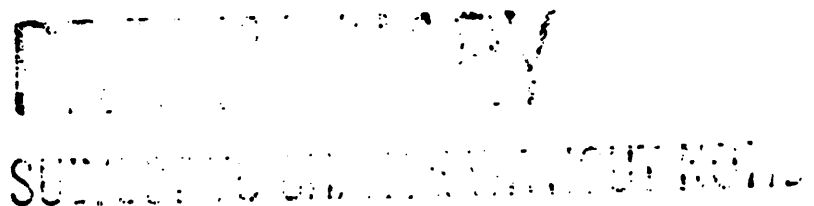

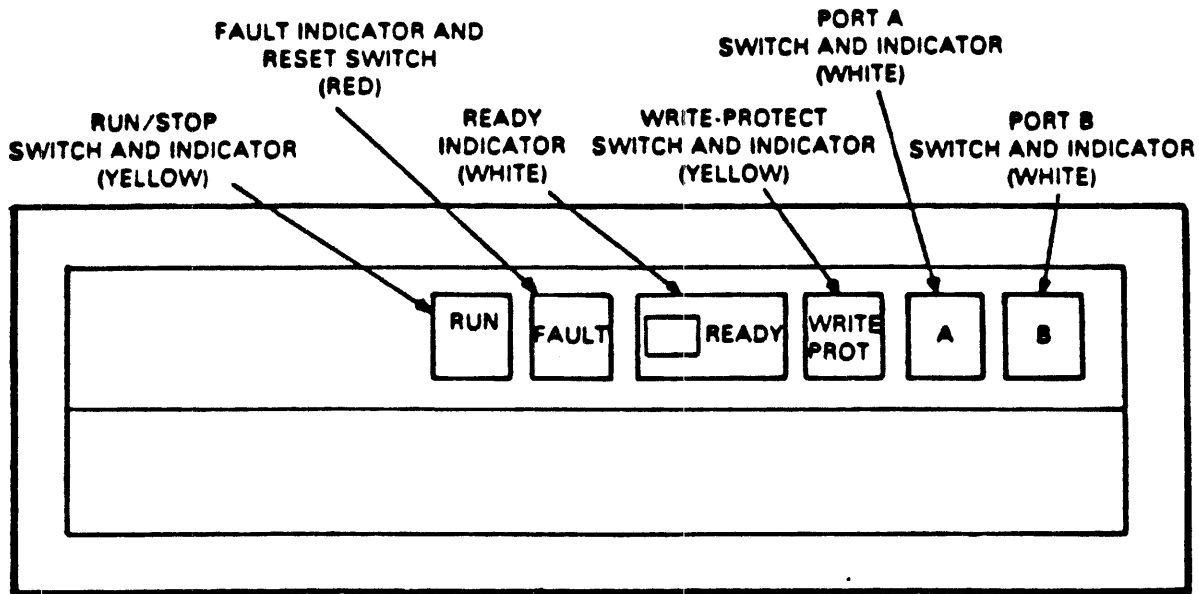

Figure 1 Front-Panel Controls and Indicators

PRELIMINARY

SUBJECT TO CHANGE WITHOUT NOTICE

PRELIMINARY
SUBJECT TO CHANGE WITHOUT NOTICE

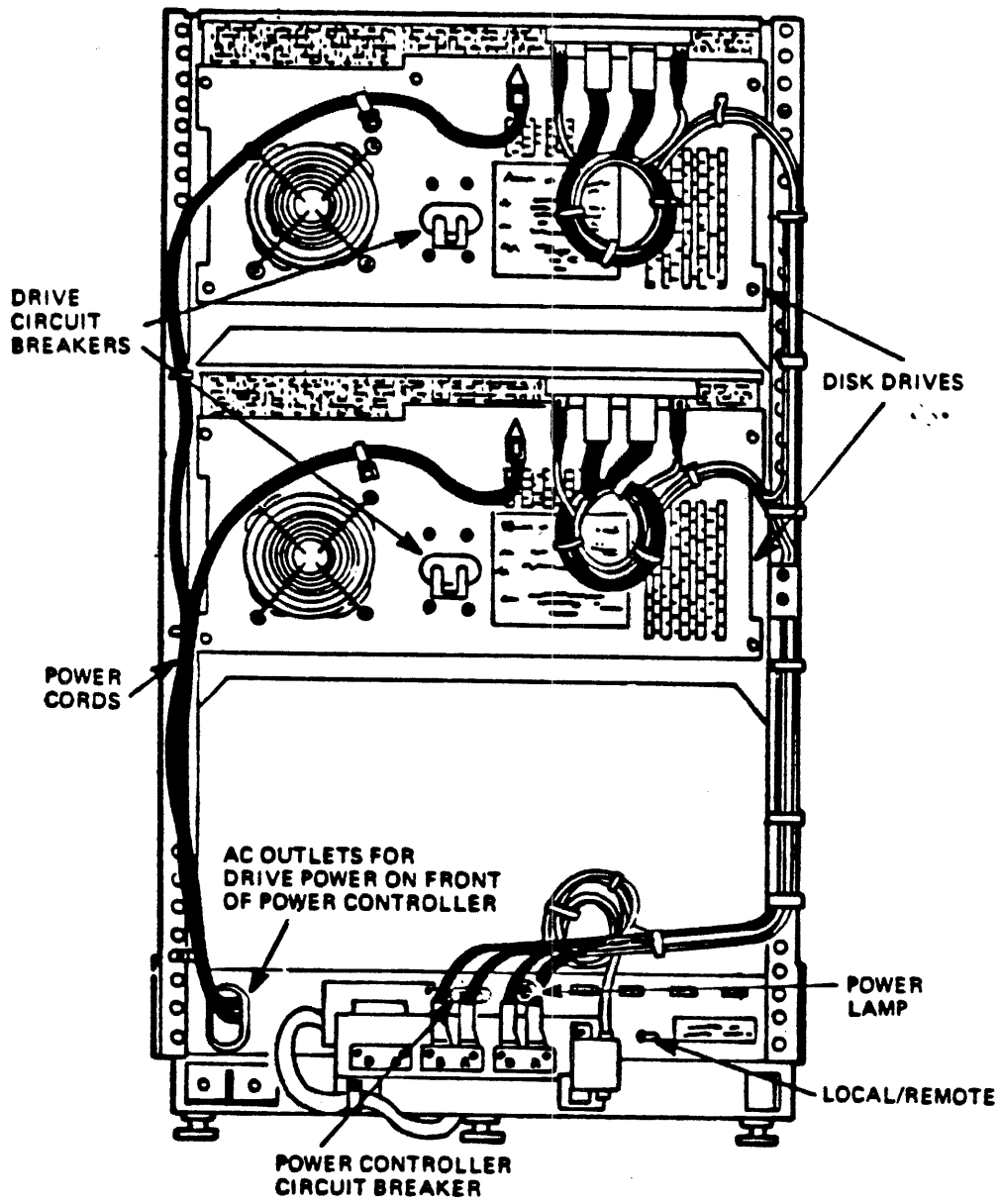

Figure 2 BACK OF AN RA81 DRIVE

FIGURE 3
STABILIZER BAR

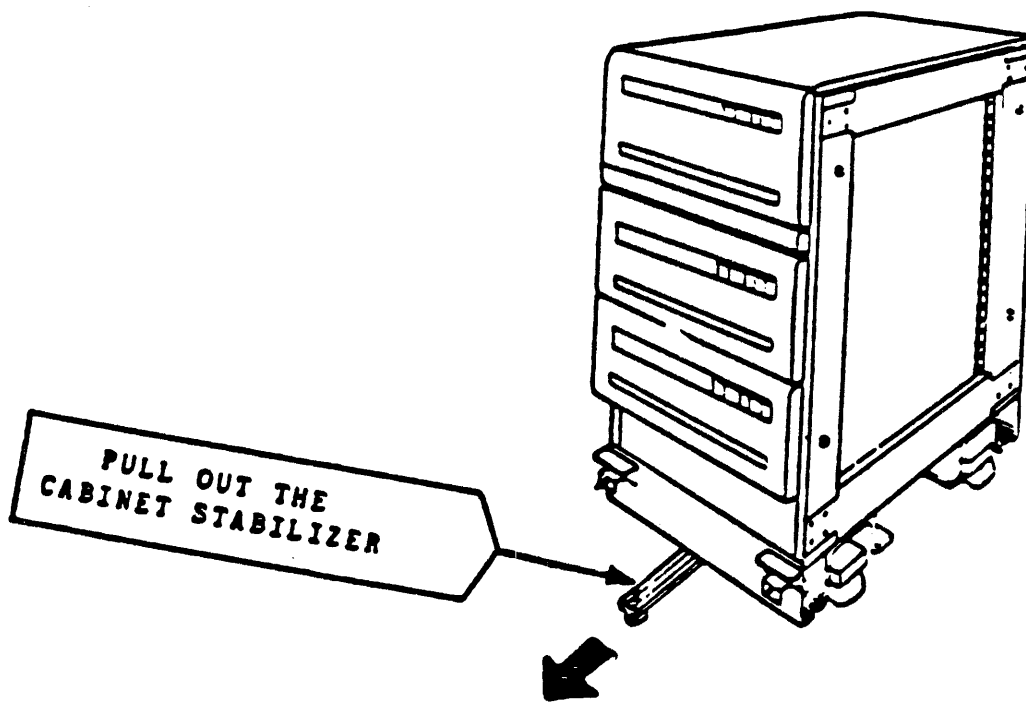

FIGURE 3
STABILIZER BAR

PRELIMINARY

SUBJECT TO CHANGE WITHOUT NOTICE

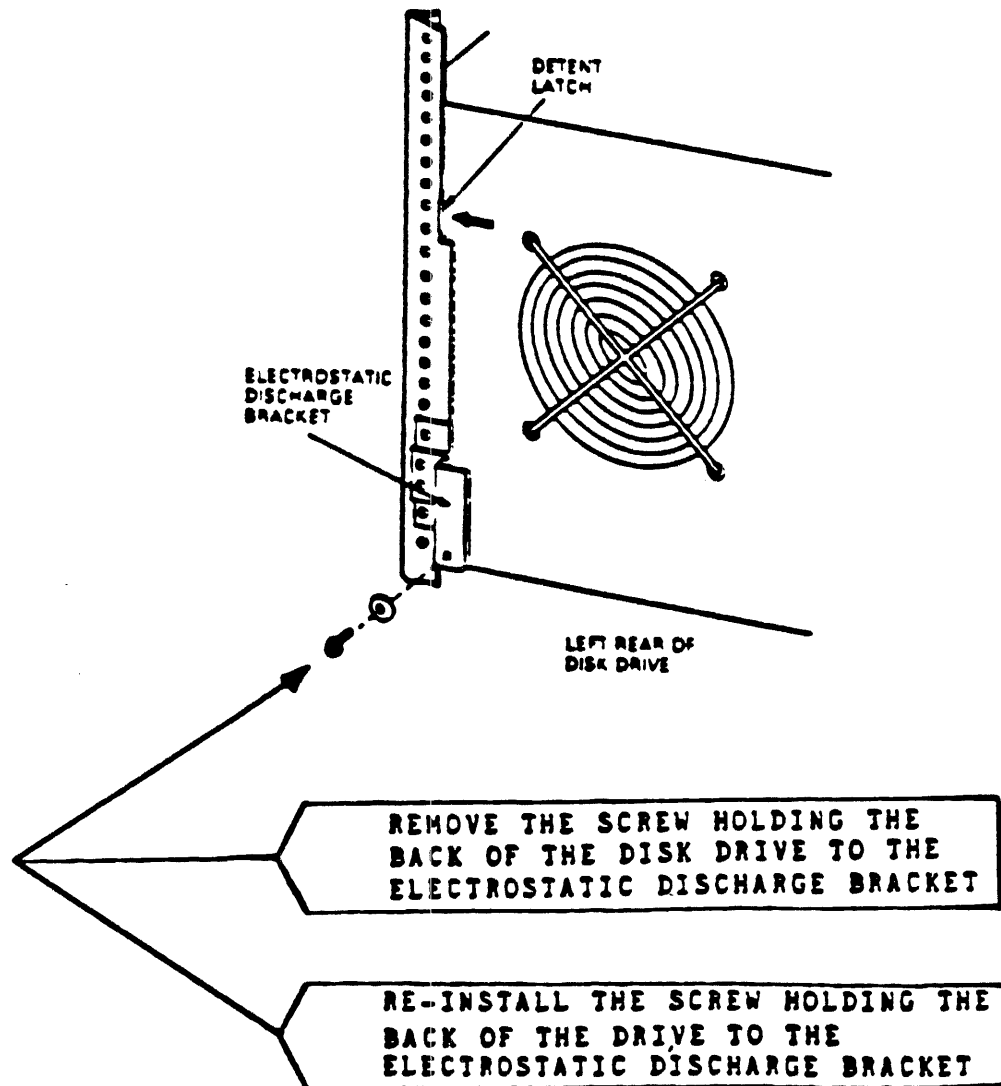

FIGURE 4
ELECTRO DISCHARGE BRACKET

PRELIMINARY

SUBJECT TO CHANGE WITHOUT NOTICE

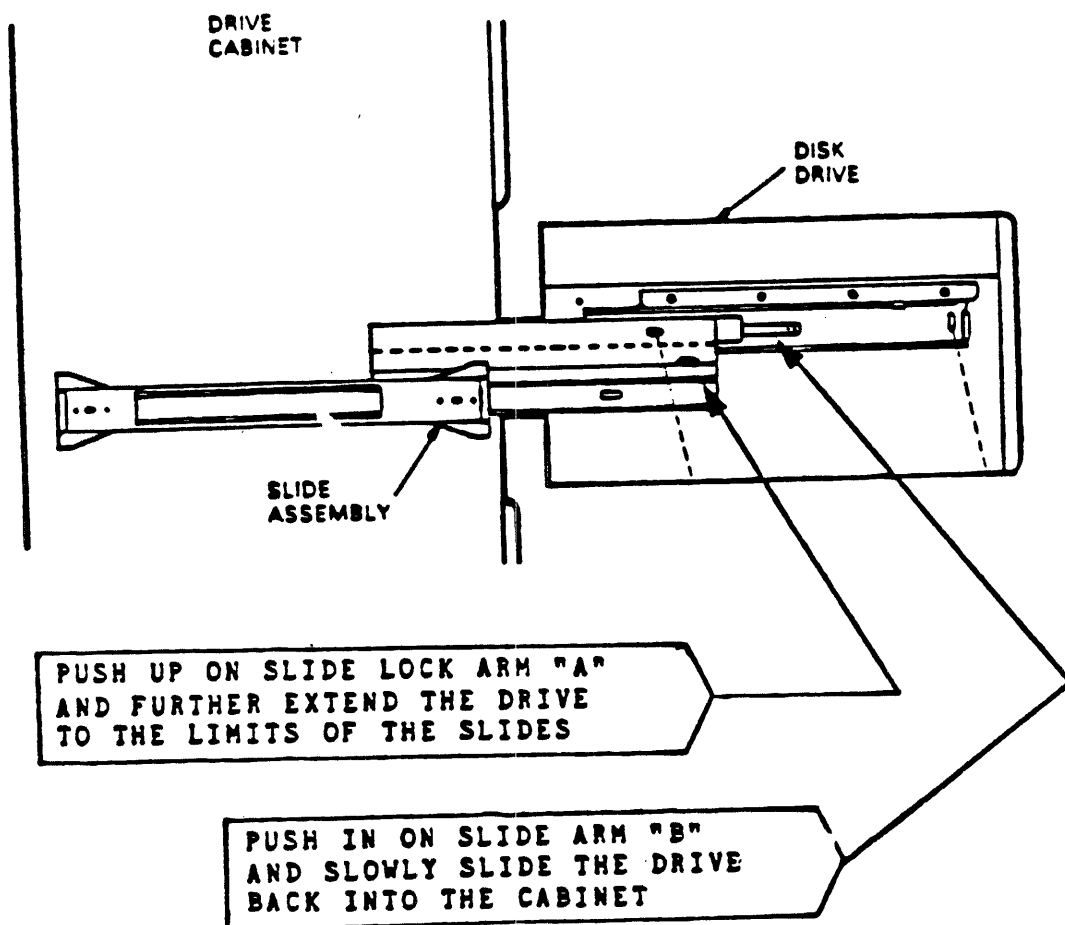

FIGURE 5

DRIVE SLIDE ARMS

PRELIMINARY

SUBJECT TO CHANGE WITHOUT NOTICE

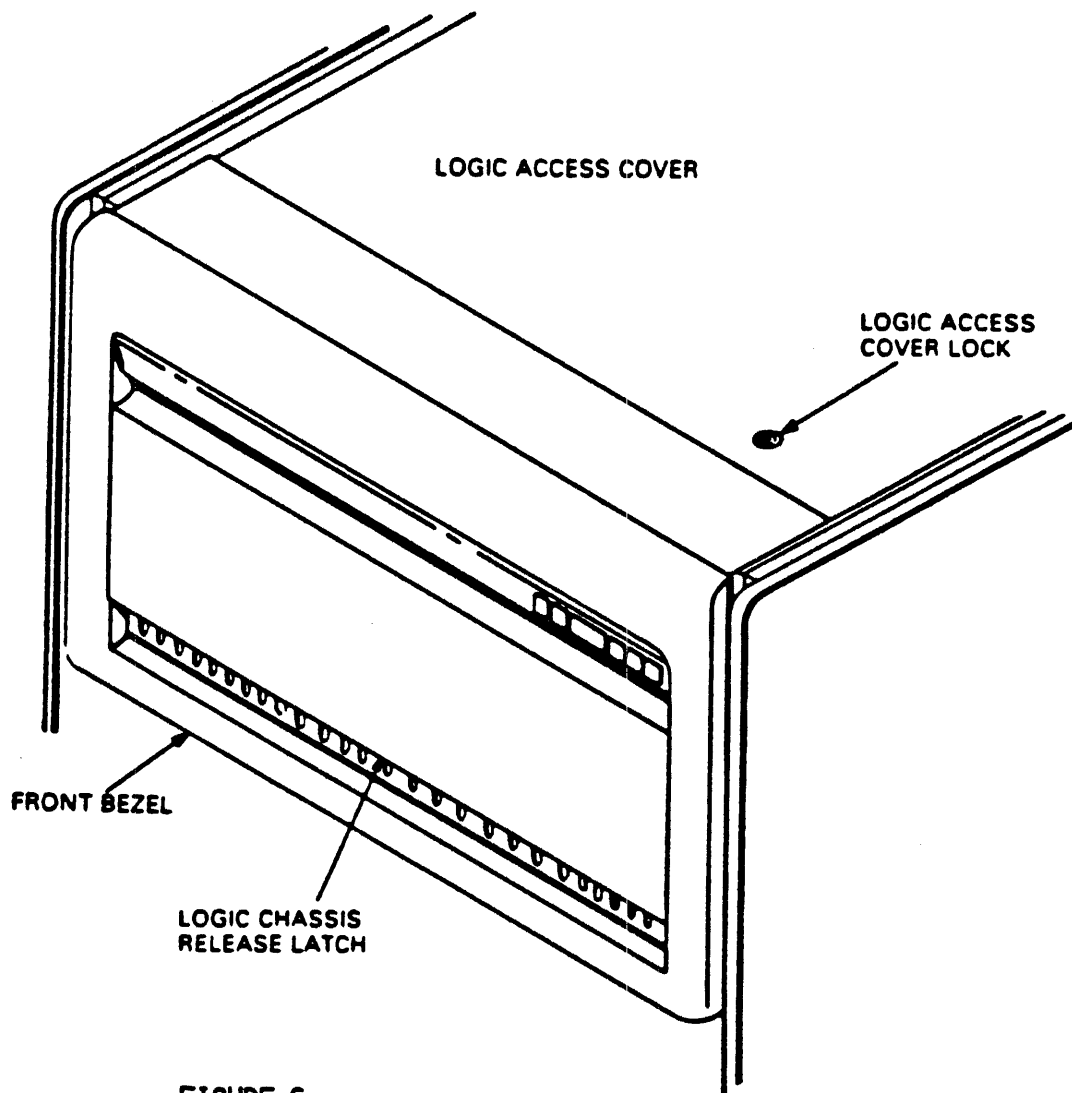

FIGURE 6
LOGIC CHASSIS RELEASE LATCH

PRELIMINARY

SUBJECT TO CHANGE WITHOUT NOTICE

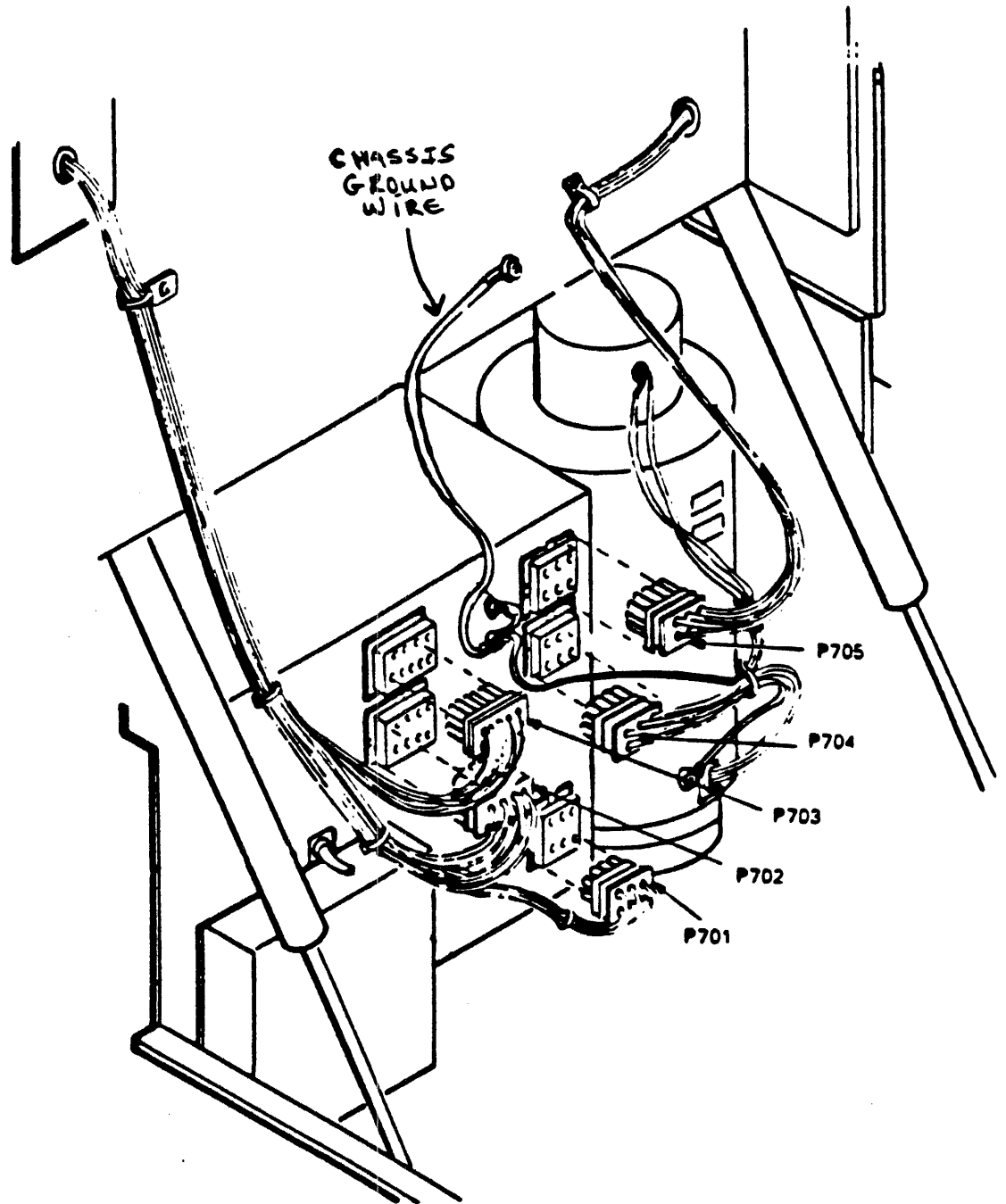

FIGURE 7
GROUND WIRE

PRELIMINARY

SUBJECT TO CHANGE WITHOUT NOTICE

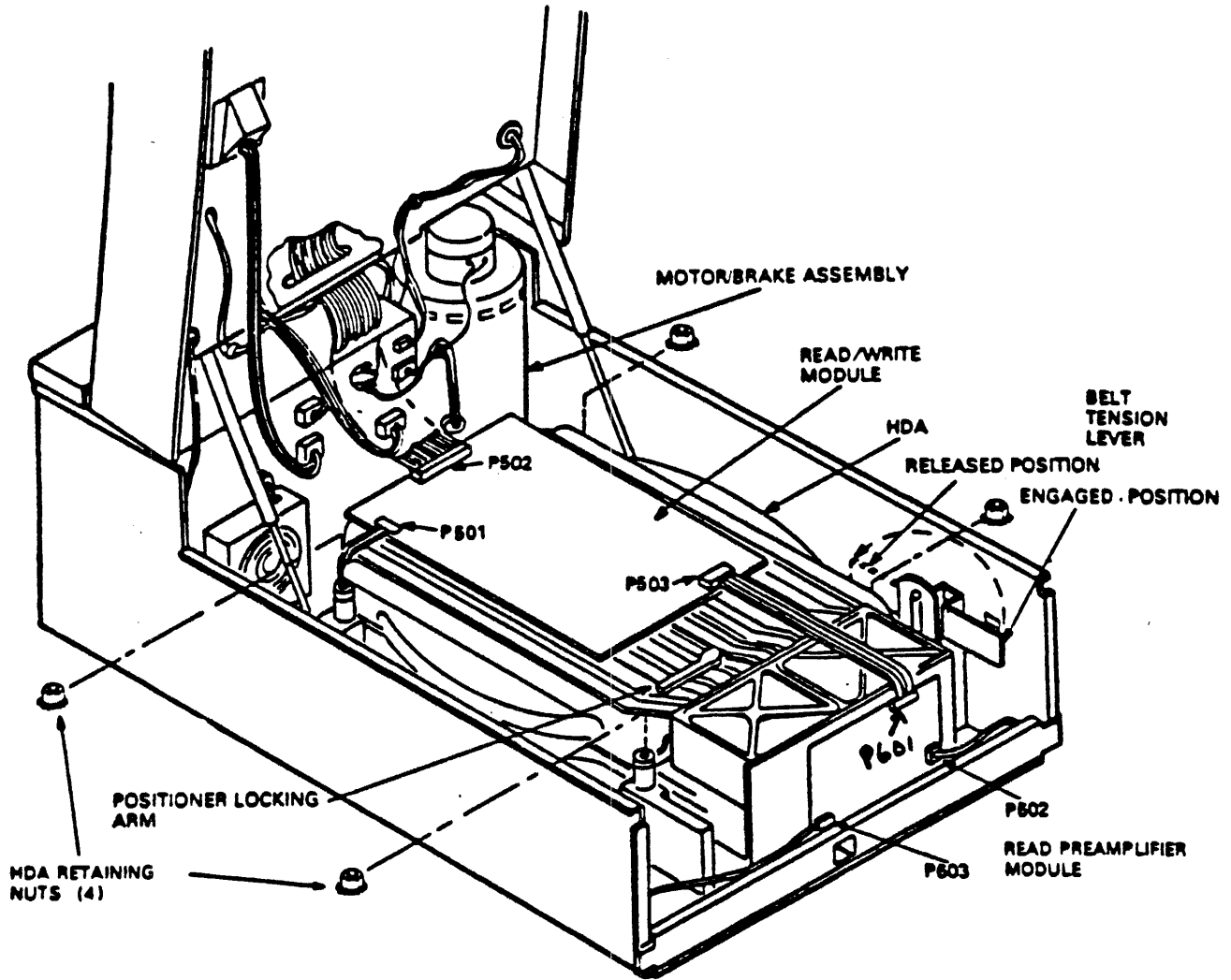

FIGURE 8

PRELIMINARY

SUBJECT TO CHANGE WITHOUT NOTICE

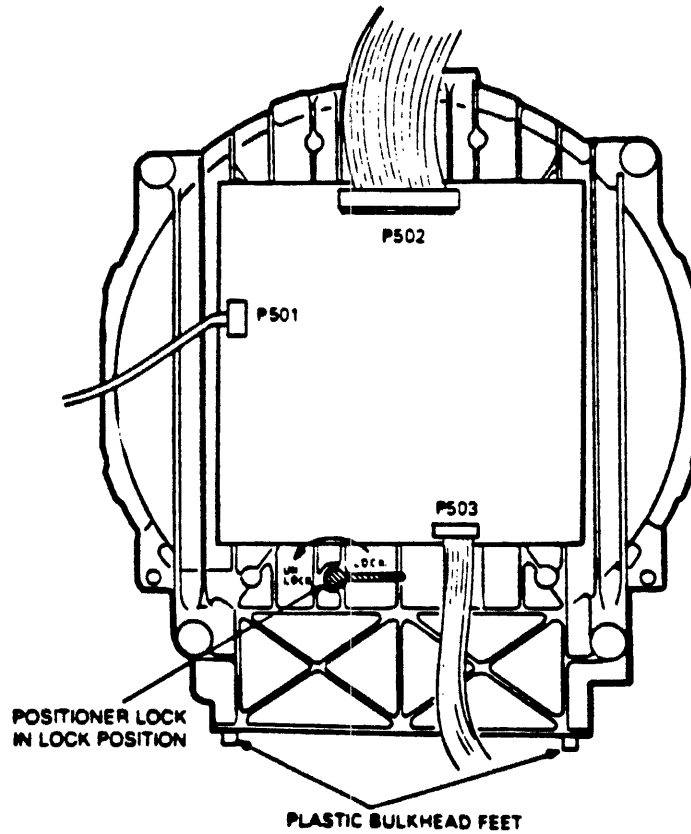
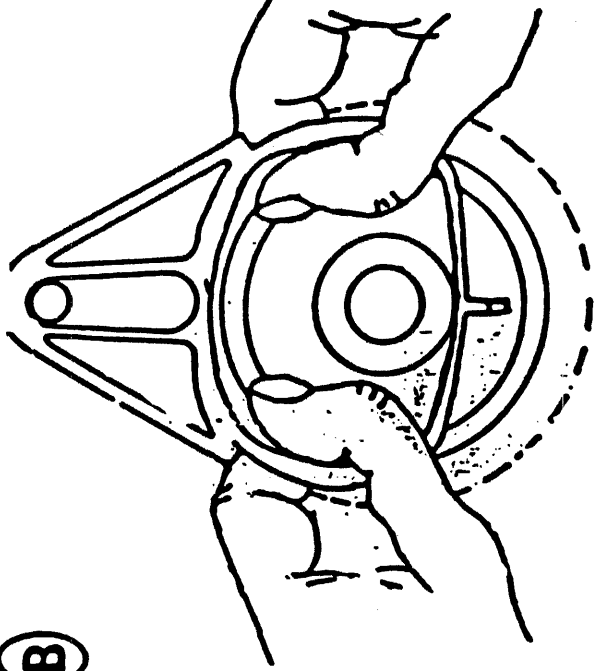

FIGURE 9

PRELIMINARY

SUBJECT TO CHANGE WITHOUT NOTICE



(B)

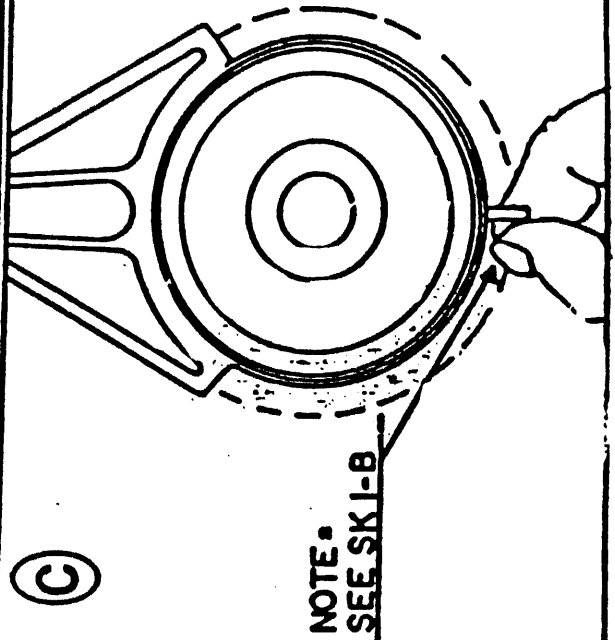

(C)

**NOTE •
SEE SKI-B**

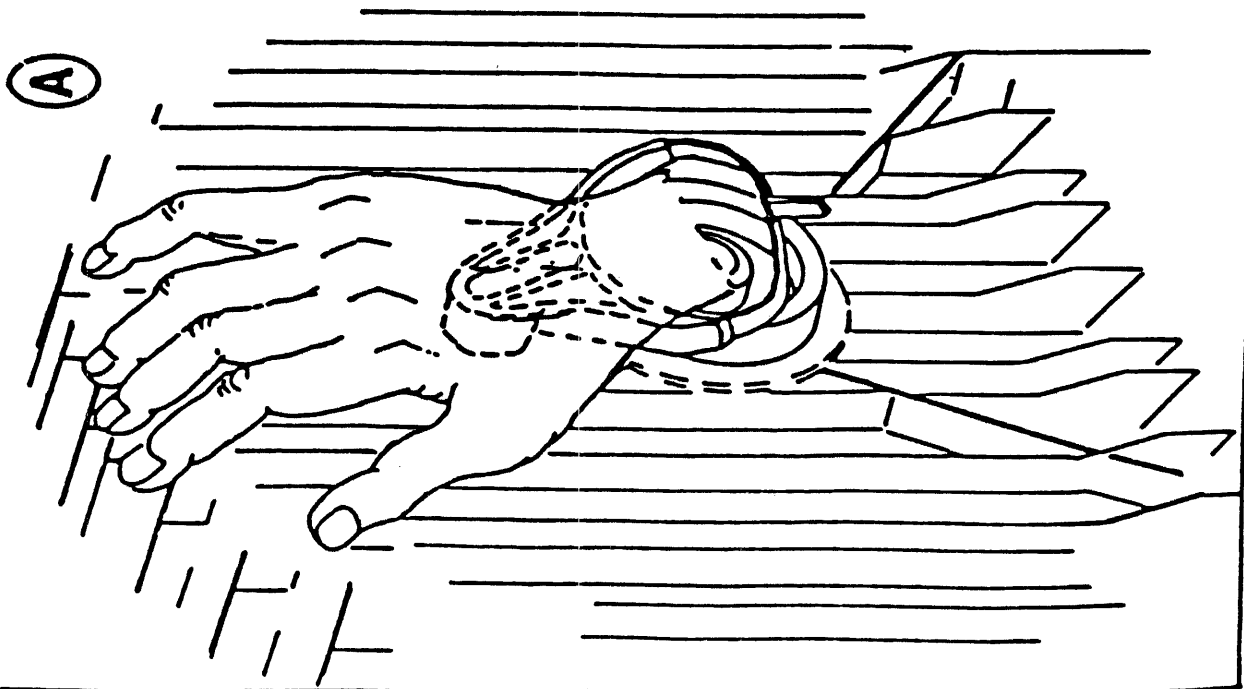

(A)

ELASTIC PULLEY LOCK

FIGURE 10

APPENDIX A

EN-10931-12-REV(B) (2/82)

REPORT NO. 7978274

FOR USA/GIA

Digital

LARS REPORT

PAGE OF

CUSTOMER NAME	FOR USA/GIA		
EQUIPMENT LOCATION (CITY AND STATE)			
EMPLOYEE G.O.	EMPLOYEE LAST NAME	ARE YOU ASSIGNED PRESENT (Y OR N)	IS CALL COMPLIANT (Y OR N)
PROB. LINE	SYSTEM/PROCESSOR TYPE	SYSTEM SERIAL NUMBER	SEC NUMBER
REQUEST TIME	REQUEST DATE MONTH YEAR	START TIME	STOP TIME
TRAVEL TIME	START DATE MONTH YEAR	START DATE MONTH YEAR	STOP DATE MONTH YEAR
DEC OPTION	VARIANT	DEC OPTION SER. NO.	FAIR AREA - MODULE - FOO - COMMENTS
A			RA81-FR-013
B			
C			
D			

SALES CODE (Circle One)	INITIAL	DEPT	INITIAL	PERCENT	UNIT
	A	D	E	G	U
CUSTOMER CODE	STATE	TAX EXEMPT	YES	NO	
IF YES, EXEMPTION CERTIFICATE MUST BE ON FILE WITH DIGITAL OR SHOULD ACCOMPANY THIS REPORT					
TAX EXEMPT NO.					

LABOR HOURS	PER HOUR	
LABOR HOURS		
TOTAL LABOR COST		
TOTAL MATERIAL COST		
TRAVEL COST		
SUB TOTAL (ALL SHOWN AHEAD)		
TO BE FILED IN B.B.N. ONLY		
LABOR %		
MATERIAL %		
TOTAL		

QTY.	CLASS	SEC PART NUMBER	VARIANT	PART DESCRIPTION - VENDOR PART NO.	AMOUNT
TOTAL MATERIAL COST					
LOGISTICS APPROVAL					
CUSTOMER BILL TO ADDRESS					
STREET					
CITY					
ATTENTION					
STATE					
ZIP					

AUTHORIZED CUSTOMER SIGNATURE _____

PRINT SIGNATURE NAME _____

CUSTOMER P.O. NO. _____

BRANCH APPROVAL _____

APPENDIX B

WAS THIS FCO A RESULT OF A FAILURE OF THE HDA _____ OR
REPLACED AS PART OF THE FCO PROGRAM? _____?

PLEASE WRITE IN THE SERIAL NUMBER OF THE DRIVE IN WHICH THIS HDA IS
BEING PLACED INTO _____ AND THE NEW H1 HDA
SERIAL NUMBER _____.

PLEASE INCLUDE THIS FORM WITH THE RETURN OF THE OLD HDA TO YOUR
LOGISTICS DEPARTMENT.

PRELIMINARY

SUBJECT TO CHANGE WITHOUT NOTICE

FCO COVER SHEET FOR RA81X-R-0009

FCO # RA81X-R0009

HOURS : 1.0

QUICK CHECK : Presence of 0.1 ufd capacitor at location C29 AND
38.3 ohm resistor at location R64 on the Read/Write
Module.

LAST PREVIOUS FCO : RX81X-R0008

RELATED or
PREREQUISITE FCO's : RA81X-S004, R/W module (54-15253) must be at CS
Revision level "D" before installation of this FCO.

APPLICABILITY : Retrofit drives where problem is evident.

Drives affected are Serial Number CX30400 and below
for 60hz and Serial Number CX6580 and below for 50hz.

The minimum acceptable revision of the 54-15253 in
spares stock is ETCH REVISION "B", CS REVISION "F1".

SPECIAL TEST EQUIPMENT, VELOSTAT KIT (Anti-Static) P/N = 29-11762-00
TOOLS, or SUPPLIES :

FIELD INSTALLATION
and TEST PROCEDURE See attached "REWORK PROCEDURES"

NOTE : This FCO implements the following ECO's:

5415253-CX004
5415253-CX005

COMPATABILITY : This FCO "MUST" be installed prior to any installation
of revision "E1" (or higher) HDA (70-18491-xx) into a
drive.

PROBLEM SYMPTOM : High rate of error codes 62 and/or 63.

Intermittent, unexplained bursts of ECC errors

Need higher write current with Rev E1 or higher HDA
assembly (70-18491-xx)

LOGISTICS :

QTY	PART NUMBER	DESCRIPTION
1	10-13466-22	0.1 mfd 50v Capacitor
1	13-05121-00	38.3 ohm resistor, 1/4 watt, 1%
	EO-01275-01	Parts + Documentation
	FA-04544-01	Documentation only

PRELIMINARY

SUBJECT TO CHANGE WITHOUT NOTICE

REWORK PROCEDURE for FCO # RA81X-R0009

1. Request that the customer release the system and the RA81 drive.
2. Depress the "A" AND the "B" port switches on the operator control panel (on the front of the drive) to the "OUT" position.
3. Spin down the drive by depressing the "RUN/STOP" switch on the operator control panel (on the front of the drive) to the "OUT" position.
4. Open the back door to the cabinet.
5. Press the drive AC circuit breaker "down" to the OFF position.
6. If the drive is fixed mounted (top drive), proceed to rework step 11.
7. Pull out the cabinet stabilizer. (Figure 1)

```
*****\*****  
*  
*          CAUTION          *  
*  
*  NEVER SLIDE A DRIVE OUT OF THE CABINET  *  
*  WITHOUT FIRST EXTENDING THE CABINET STABILIZER *  
*  
*****
```

8. Remove the screw holding the back of the disk drive to the electrostatic discharge bracket. (Figure 2)
9. Slowly pull the drive out on its slides until it locks into place.
10. Push up on slide lock arm "A" and further extend the drive to the limits of the slides. (Figure 3)
11. Push the logic chassis release latch with a screwdriver. (Figure 4)
12. Raise the drive chassis to a completely raised position. (Figure 5)
13. Before proceeding, ensure that the VELOSTAT Anti-static Kit (p/n = 29-11762-00) is being properly utilized during any handling of the R/W module.
14. Remove the Read/Write Module, p/n 54-15253. (Figure 5)
15. Remove C29 (0.01 ufd, 50v capacitor). (Figure 6)
16. Install C29 (0.1 ufd, 50v capacitor, p/n 10-13466-22) supplied in the FCO Kit. (Figure 6)

PRELIMINARY

SUBJECT TO CHANGE WITHOUT NOTICE

17. Remove R64 (51.1 ohms, 1/4 watt, 1%, resistor). Refer to Figure 6. This resistor may be identified by the marking "51R1" OR color-coded with the color bands "Green-Brown-Brown-Gold-Brown".
18. Install R64 (38.3 ohms, 1/4 watt, 1% resistor, p/n 13-05121-00) supplied in the FCO Kit. Refer to Figure 6. This resistor may be identified by the marking "38R3" OR color-coded with the color bands "Orange-Grey-Orange-Gold-Brown".
19. When the above rework is complete, mark the module "CS Revision F1".
20. Re-Install the reworked R/W module back into the drive.
21. Lower the drive chassis until the chassis latch engages.
22. If the drive is fixed mounted (top drive), proceed to rework step 25.
23. Push in on Slide Arm "B" and slowly slide the drive back into the cabinet. (Figure 3)

24. *****
 *
 * CAUTION *
 *
 * RE-INSTALL THE SCREW HOLDING THE BACK OF THE *
 * DRIVE TO THE ELECTROSTATIC DISCHARGE BRACKET *
 *
 * (Figure 2) *
 *

25. Raise the drive AC Circuit breaker (at the rear of the drive) up to the "ON" position
26. Close the back door of the cabinet.
27. Depress the "WRITE/PROT" switch on the operator control panel to the "OUT" position.
28. Spin up the drive by pressing the RUN/STOP switch on the operator control panel (on the front of the drive) to the "IN" position.
29. Observe the "READY" lamp on the operator console and verify that it illuminates after about 60 seconds.

PRELIMINARY
 SUBJECT TO CHANGE WITHOUT NOTICE

30. Observe the "READY" lamp on the operator console and verify the following:
 - a) The "READY" lamp should extinguish (go out) approximately every 30 seconds.
 - b) The "READY" lamp should re-illuminate (go on) approximately every 30 seconds.

This process allows the drive internal "idle" diagnostics to recycle as long as the "Port Switches" and Write Protect switch are released.

31. Verify that the "FAULT" lamp DOES NOT illuminate during several cycles of the process described in step 30 above.
32. Press the "A" and/or "B" port switches on the operator control panel (on the front of the drive) to the "IN" position
33. Run EVRLA (VAX diagnostic) or CZUDC (PDP11 diagnostic) to insure proper operation of the drive.
34. Return the drive and system to the customer.
35. Log this FCO activity into the Digital Site Management Guide.

PRELIMINARY
SUBJECT TO CHANGE WITHOUT NOTICE

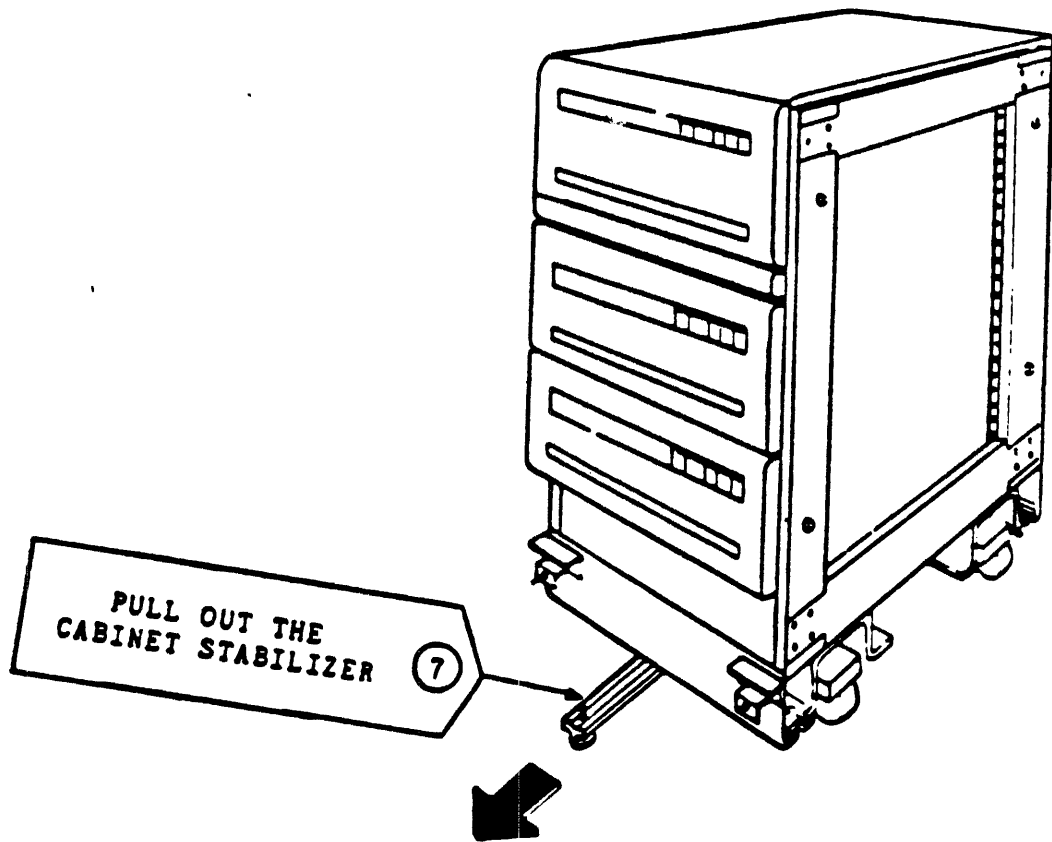

PRELIMINARY
SUBJECT TO CHANGE WITHOUT NOTICE

Figure 1

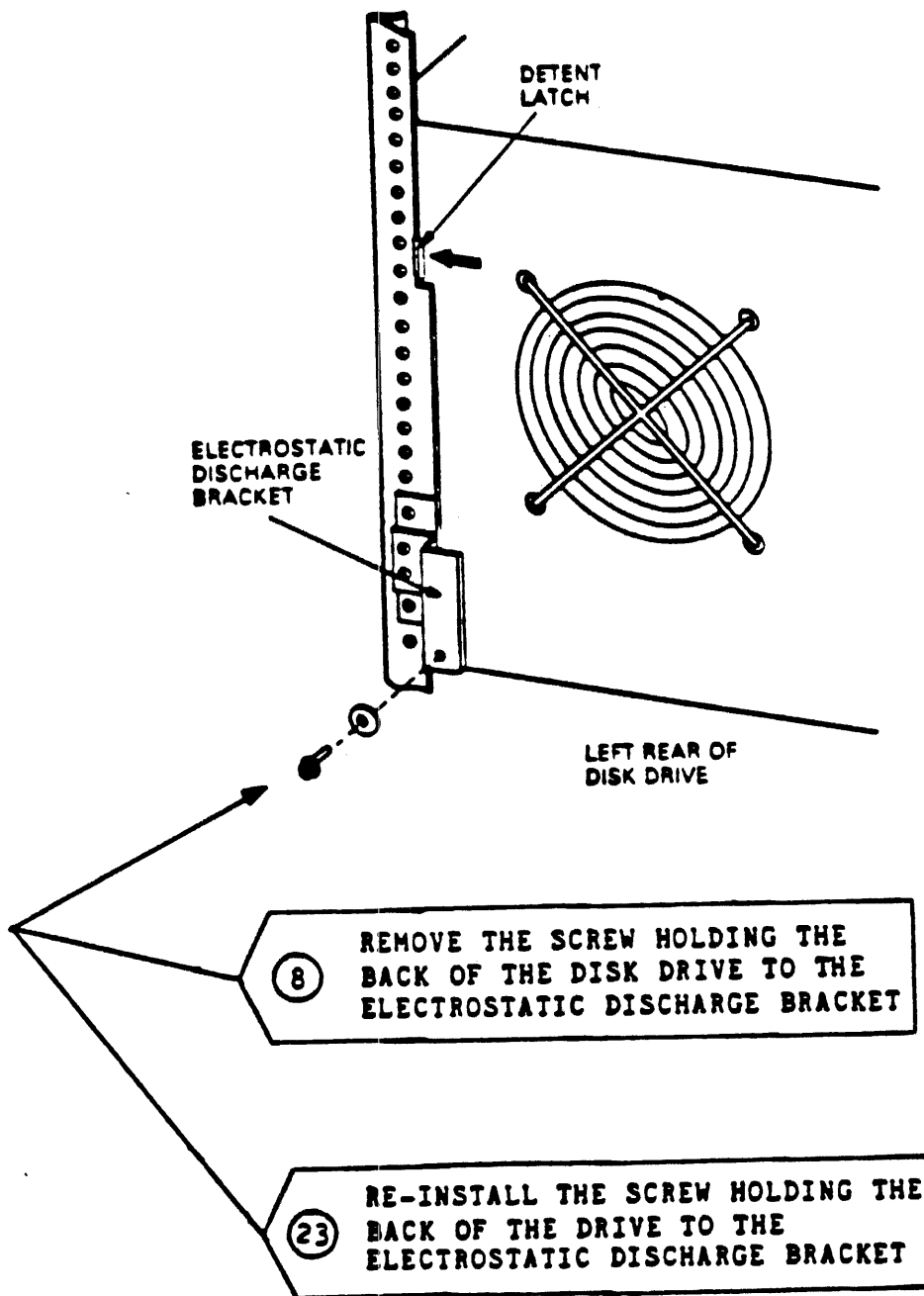

PRELIMINARY
SUBJECT TO CHANGE WITHOUT NOTICE

Figure 2

PRELIMINARY

SUBJECT TO CHANGE WITHOUT NOTICE

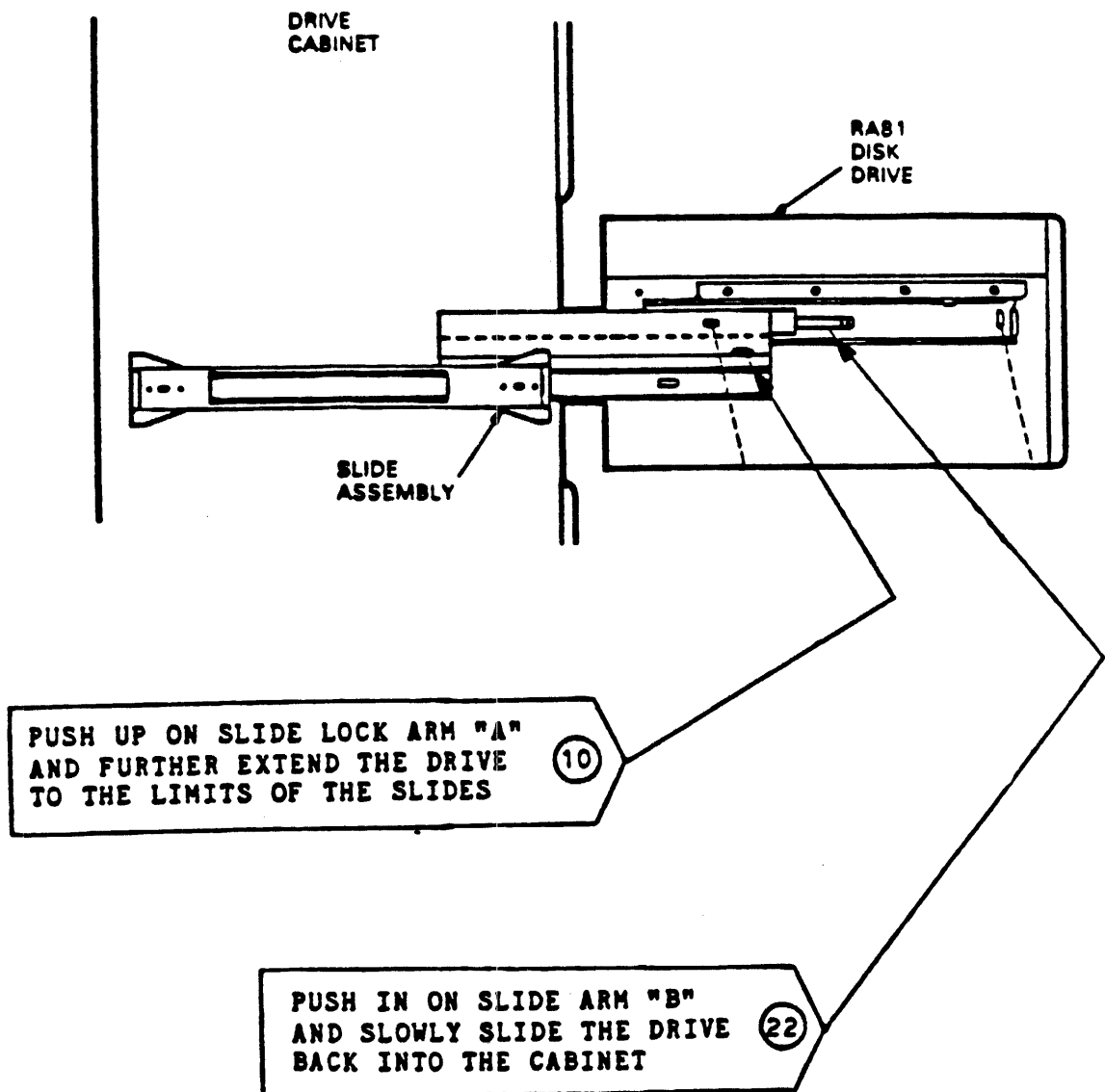

Figure 3

PRELIMINARY

SUBJECT TO CHANGE WITHOUT NOTICE

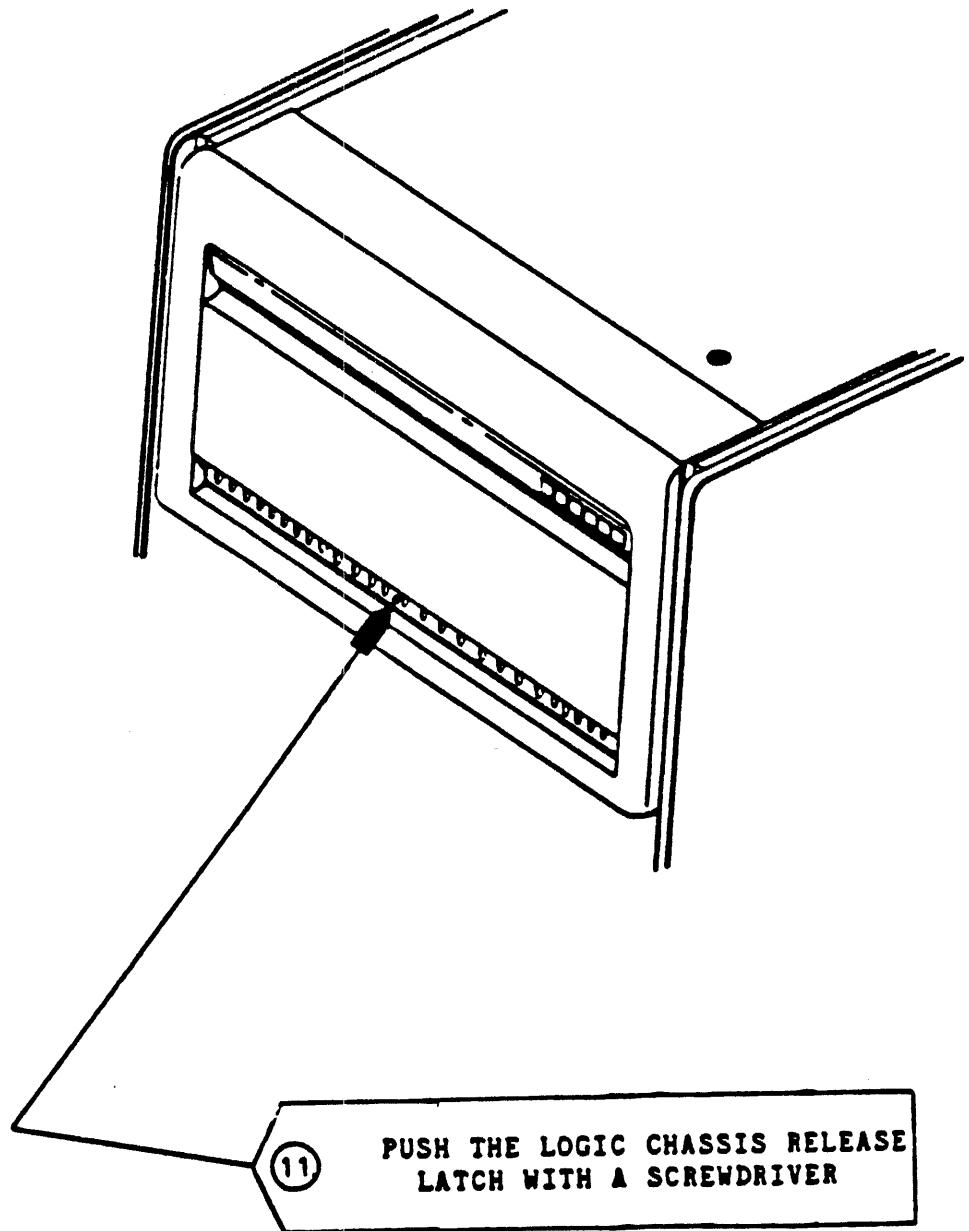
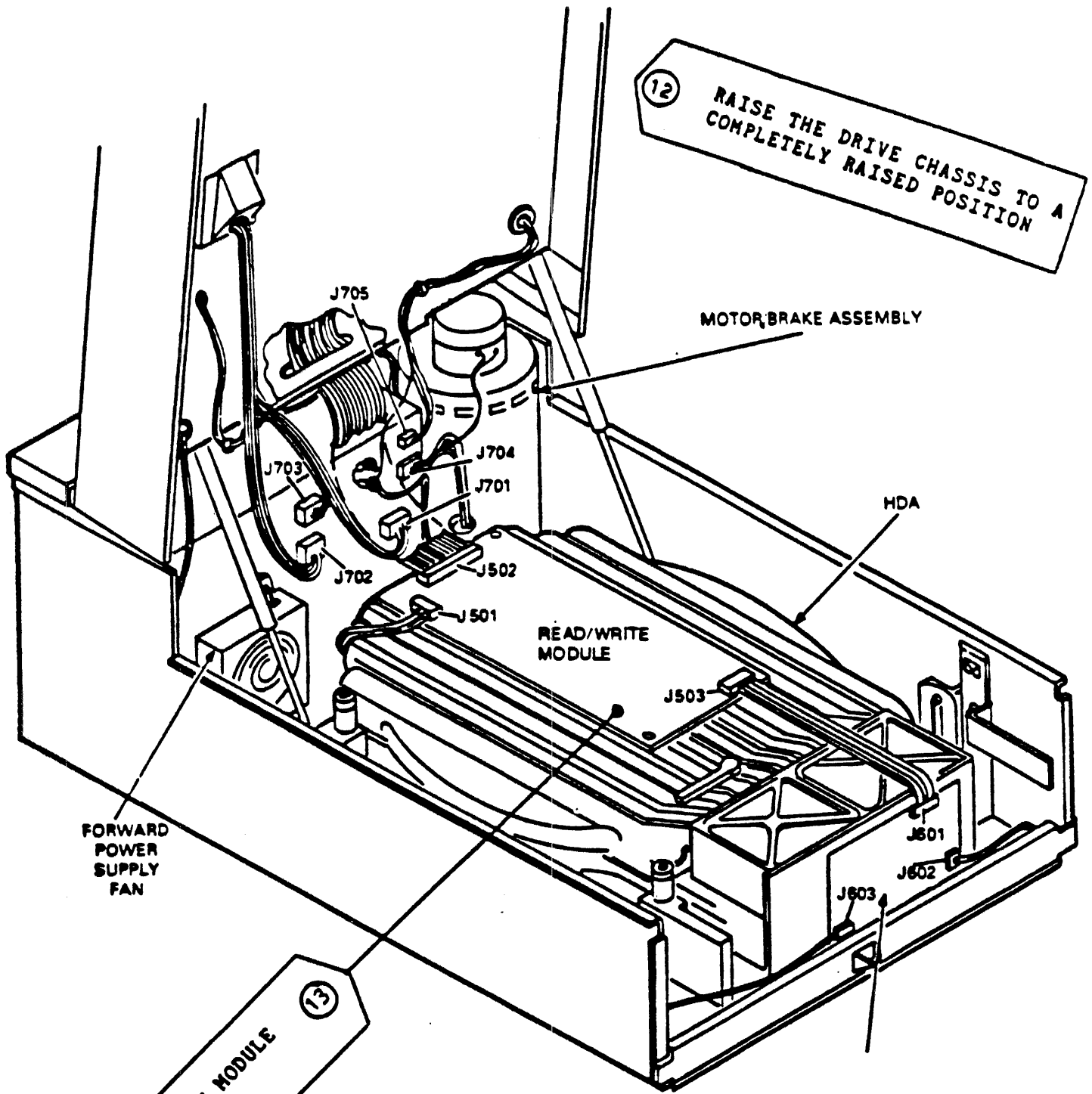

Figure 4



12 RAISE THE DRIVE CHASSIS TO A COMPLETELY RAISED POSITION

MOTOR, BRAKE ASSEMBLY

HDA

READ/WRITE MODULE

FORWARD POWER SUPPLY FAN

13 REMOVE THE R/W MODULE P/N 54-15253

PRELIMINARY

SUBJECT TO CHANGE WITHOUT NOTICE

Figure 5

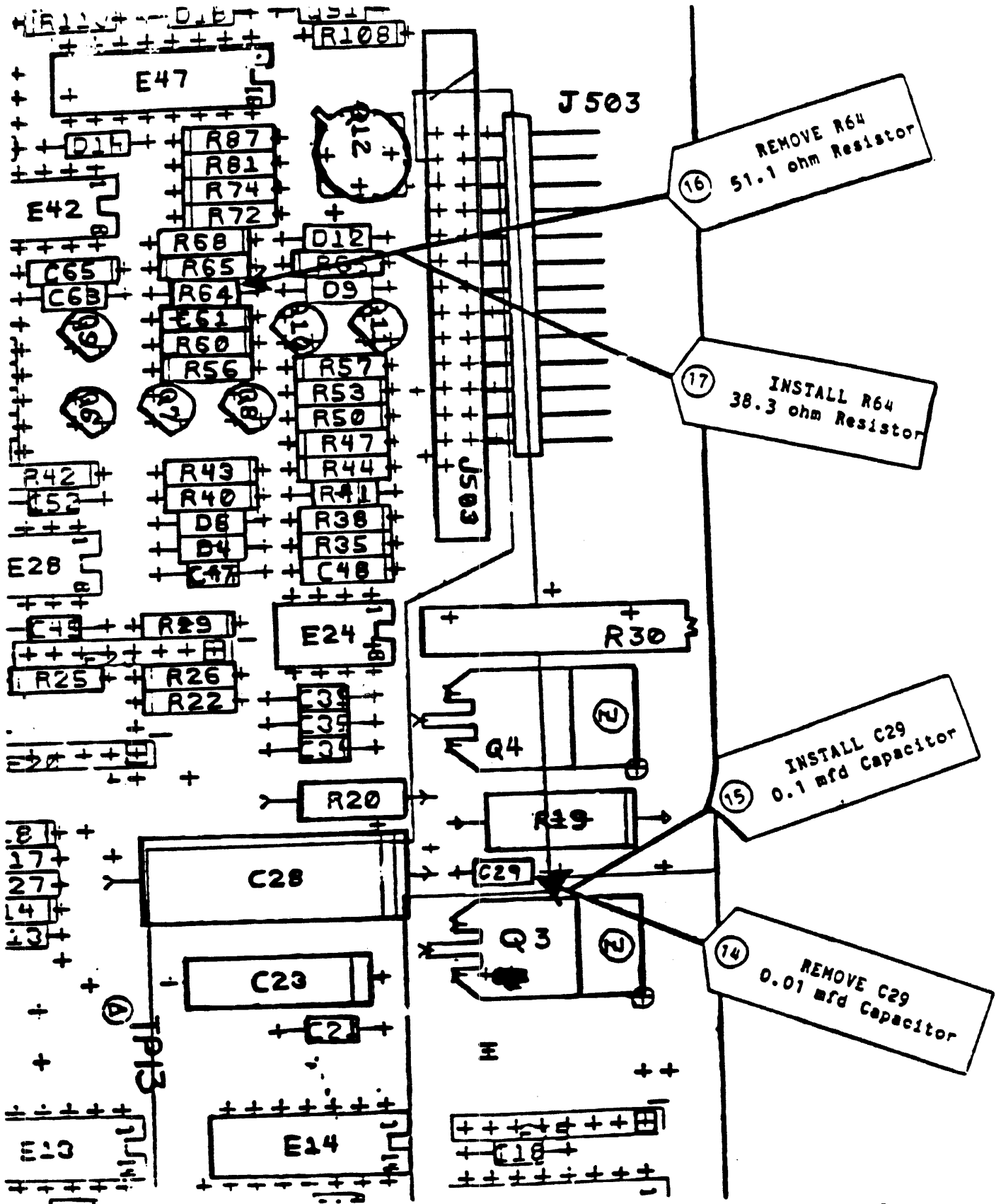

Figure 6 **PRELIMINARY**
 SUB PAGE WITHOUT NOT

digital

FCO RA81X-R-012

Level of Urgency

+---+
| R |
+---+

Page ___
Of ___

FIELD CHANGE ORDER

Number: RA81X-R-012

Applicability: REWORK ALL RA81 MICROPROCESSOR MODULES:
ETCH REVISION "B" CS REVISION "K" OR LOWER
REVISION "C1" CS REVISION "L3" OR LOWER

Problem/Symptom:

POTENTIAL ECC ERRORS ON THE RA81

Quick Check:

SEE PAGE 2 OF THIS FCO

Compatibility/Prerequisite FCO:
NONE

Est. Time to Install:
1.5

Special Tools or Test Equipment: VELOSTAT KIT (ANTI STATIC) PART NUMBER
29-11762-00. ZERO OHM JUMPERS PART NUMBER 90-09185-00

FCO Parts Information

Order by FCO Kit#:	Quantity:	Part Number:	Description:
FA-04649-01	1	FA-04649-01	FCO DOCUMENTATION

EQ Kit Variation System/Option Applic:

Approvals

CSSE Engineer KEITH BROWN	F.S. Product Safety	F.S. Logistics
CSSE Manager RON MILANO	F.S. Microfiche Libraries	Affected Population:
ESD&P Micropub.		Initial Kitting:
Revision:		Hardcopy Publication:
FCO Release Date		Parts Availability:

PREPARED BY
SUE...

*** PLEASE NOTE ***

THIS ADJUSTMENT SHOULD ONLY BE PERFORMED ON MICROPROCESSOR MODULES WITH A
ETCH REV "C1", C.S. REV "L3" OR LOWER, AND ETCH REV "B", C.S. REV "K".

*
* MICROPROCESSOR MODULES WITH AN ETCH "B", C.S. "K1" OR ETCH "C1", C.S. "M1"
* REVISIONS SHOULD NOT BE ADJUSTED. RA81'S AT HARDWARE REVISION 6 WILL HAVE
* THE "M1" OR THE "K2" MICROPROCESSOR.

THE C.S. REVISION MARKING IS LOCATED IN THE UPPER LEFT (COMPONENT SIDE) PORTION
OF THE MODULE. THIS MARKING WILL INCLUDE A 2 OR 3 DIGIT DATA CODE AND THE C.S.
REVISION LEVEL, IE; 452L3 "L3" = C.S. REVISION LEVEL, REFER TO RA81 TECH
TIP #21 SPEED BULLETIN 343 7/30/84 OR DSA RIGHT STUFF ISSUES 1 AND 2 FOR
ASSISTANCE IN LOCATING REVISION LEVELS.

BEFORE OR AFTER PERFORMING THIS ADJUSTMENT PROCEDURE, THE SITE MANAGEMENT GUIDE
MUST BE VERIFIED OR UPDATED TO REFLECT CHANGE.

FOR INFORMATION ONLY
SUBJECT TO CHANGE WITHOUT NOTICE

STEPS FOR GETTING DRIVE FROM CUSTOMER AND PREPARING FOR THE
IMPLEMENTATION OF THIS FCO

1. REQUEST THE RA81 DRIVE FROM THE CUSTOMER.
2. THE RA81 DRIVE MUST BE DISMOUNTED AND Deselected.
3. SPIN THE DRIVE DOWN BY PRESSING THE RUN/STOP SWITCH. (Figure 1)
4. AFTER THE DRIVE HAS STOPPED, TURN THE CIRCUIT BREAKER AT THE REAR OF THE RA81 TO THE OFF POSITION. (Figure 2)
5. REMOVE THE AC LINE CORD FROM THE REAR OF THE RA81 DRIVE. (Figure 2)
6. OPEN THE LOGIC ACCESS COVER LID BY TURNING THE ALLEN HEAD LATCH SCREW. (Figure 3)
7. FOLD OUT THE SEVO AND PERSONALITY MODULES. (Figure 4)
8. DISCONNECT ALL CABLES ATTACHED TO THE MICROPROCESSOR MODULE. (Figure 5)
9. REMOVE THE MICROPROCESSOR MODULE FROM THE LOGIC CHASSIS.

MICROPROCESSOR DATA SEPARATOR WINDOW ADJUSTMENT

1. THE JUMPERS ARE LOCATED ON THE MICROPROCESSOR MODULE. (Figure 6)
2. FOR PROPER JUMPER POSITION, LOCATE W7, W8, and W9, see Figure 7.
3. VERIFY THE CURRENT JUMPER SELECTION

W7 ___ W8 ___ W9 ___

4. ADD OR REMOVE JUMPERS PER TABLE LISTED BELOW USING THE JUMPER REMOVAL PROCEDURES WHICH FOLLOW THIS TABLE.

!!!THE FOLLOWING SETTINGS ARE THE ONLY ADJUSTMENTS THAT CAN BE MADE!!!!
IF ANY OTHER ADJUSTMENTS ARE PERFORMED THE DATA SEPARATOR WINDOW WILL BE
OUT OF TOLERANCE.

CURRENT SETTING	CHANGE	RESULT
W9, W8, W7 OUT	ADD W9	W9 IN
W9 IN / W7, W8 OUT	ADD W8	W8 W9 IN
W8 IN / W7, W9	ADD W7 AND W9 REMOVE W8	W7 W9 IN
W9 AND W8 IN / W7 OUT	ADD W7 REMOVE W8	W7 W9 IN

SUBJECT TO CHANGE WITHOUT NOTICE

JUMPER REMOVAL PROCEDURE

THE JUMPERS ARE SOLDEPED IN PLACE. THE REMOVAL OF THE OLD JUMPERS WILL PEQUIRE EXTREME CARE SO AS NOT TO DAMAGE THE MODULE. THE FOLLOWING STEPS ARE THE EASIEST METHOD FOR JUMPER REMOVAL. E.S.D. PROTECTION MUST BE OBSERVED AT ALL TIMES. USE THE VELOSTAT KIT (ANTI-STATIC) P/N 29-11762

AFTER THE MICROPROCESSOR HAS BEEN REMOVED FROM THE RA81 PERFORM THE FOLLOWING STEPS.

- 1. USING DIAGONAL CUTTFERS REMOVE THE EXCESS LEAD OF PREVIOUSLY REMOVED JUMPER FROM THE JUMPER EYELET ON THE COMPONENT SIDE OF THE MODULE. (FIGURE 8)
2. ADD A SMALL AMOUNT OF SOLDER TO THE COMPONENT SIDE OF JUMPER EYELET.
3. STRAIGHTEN THE JUMPER LEAD ON THE ETCH SIDE. (FIGURE 9)
4. PLACE THE MODULE UPRIGHT , PREFERABLY BETWEEN KNEES WHILE SITTING.

* !!! !!! WARNING!!!!!! *
* DO NOT APPLY HEAT TO MODULE FOR EXTENDED PERIOD. OVERHEATING *
* WILL CAUSE DAMAGE TO THE MODULE AND RENDER IT USELESS *

- 5. GRASP THE JUMPER LEAD WITH NEEDLE NOSE PLIERS OR SIDE CUTTERS. HEAT THE COMPONENT SIDE WITH A SOLDERING IRON AND PULL THE JUMPER LEAD OUT OF THE PLATED FEED THROUGH (PFT) HOLE. DO NOT FORCE THE REMOVAL.
6. ADD A SMALL AMOUNT OF SOLDER TO THE JUMPER PFT HOLE.
7. SET THE MODULE UPRIGHT, PLACE A SOLDER SUCKER ON THE ETCH SIDE OF THE JUMPER PFT HOLE. APPLY IRON TO THE SOLDER TAP ON THE COMPONENT SIDE OF THE PFT HOLE.
8. ENGAGE THE SOLDER SUCKER. ENSURE THAT ALL THE SOLDER IS REMOVED. IF NOT, PERFORM STEPS 6 AND 7 AGAIN.
9. SOLDER IN THE REQUIRED ZERO OHM JUMPER (P/N 90-09185) IN THE PFT HOLF.
10. REINSTALL THE MICROPROCESSOR MODULE INTO THE DRIVE.
11. ALLOW ALL INTERNAL DRIVE DIAGNOSTICS TO RUN TO COMPLETION BY DESELECTING BOTH PORT SWITCHES DURING SPIN UP FOR FIVE (5) MINUTES .
12. RUN AT LEAST ONE PASS RA81 DISK D IVE DIAGNOSTIC

Table with 3 columns: Bit Size, Model, and Component. Rows include 16 BIT PDP-11 (UDA50, CZUDC), 32 BIT VAX-11 (UDA50, EVKAB, HSC50, ILEXER), and 36 BIT 10/20 (HSC50, ILEXER).

13. RETURN RA81 DISK DRIVE TO THE CUSTOMER FOR SOFTWARE USE

14. LOG FCO ACTIVITY IN THE CUSTOMERS

PRELIMINARY SITE MANAGEMENT GUIDE.

SUBJECT TO CHANGE WITHOUT NOTICE.

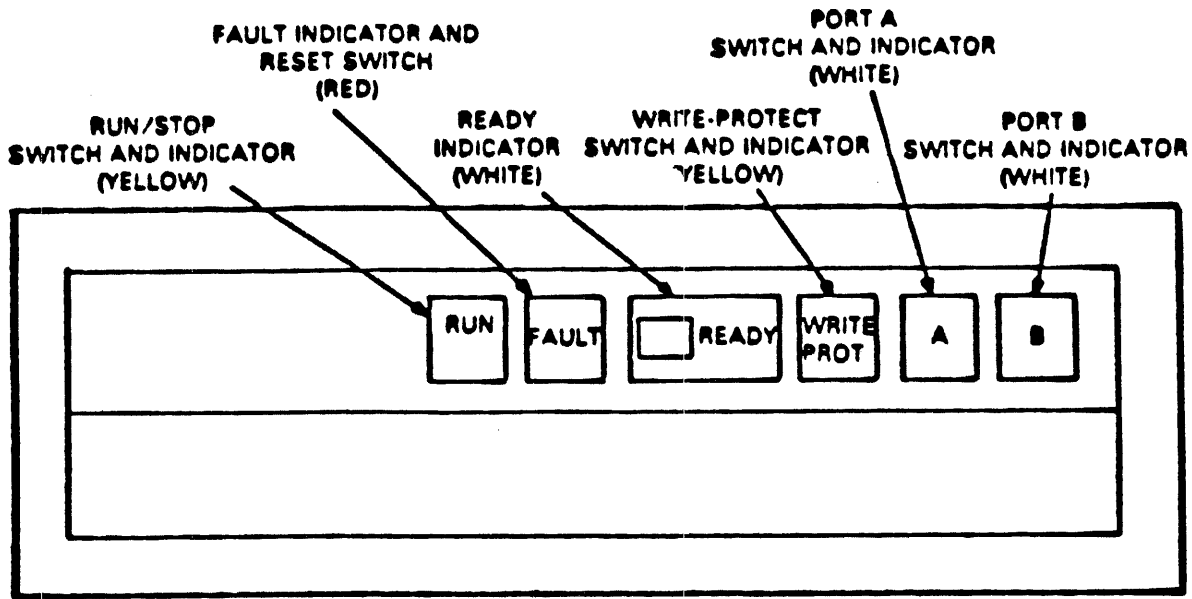

Figure 1 Front-Panel Controls and Indicators

PRELIMINARY

SUBJECT TO CHANGE WITHOUT NOTICE

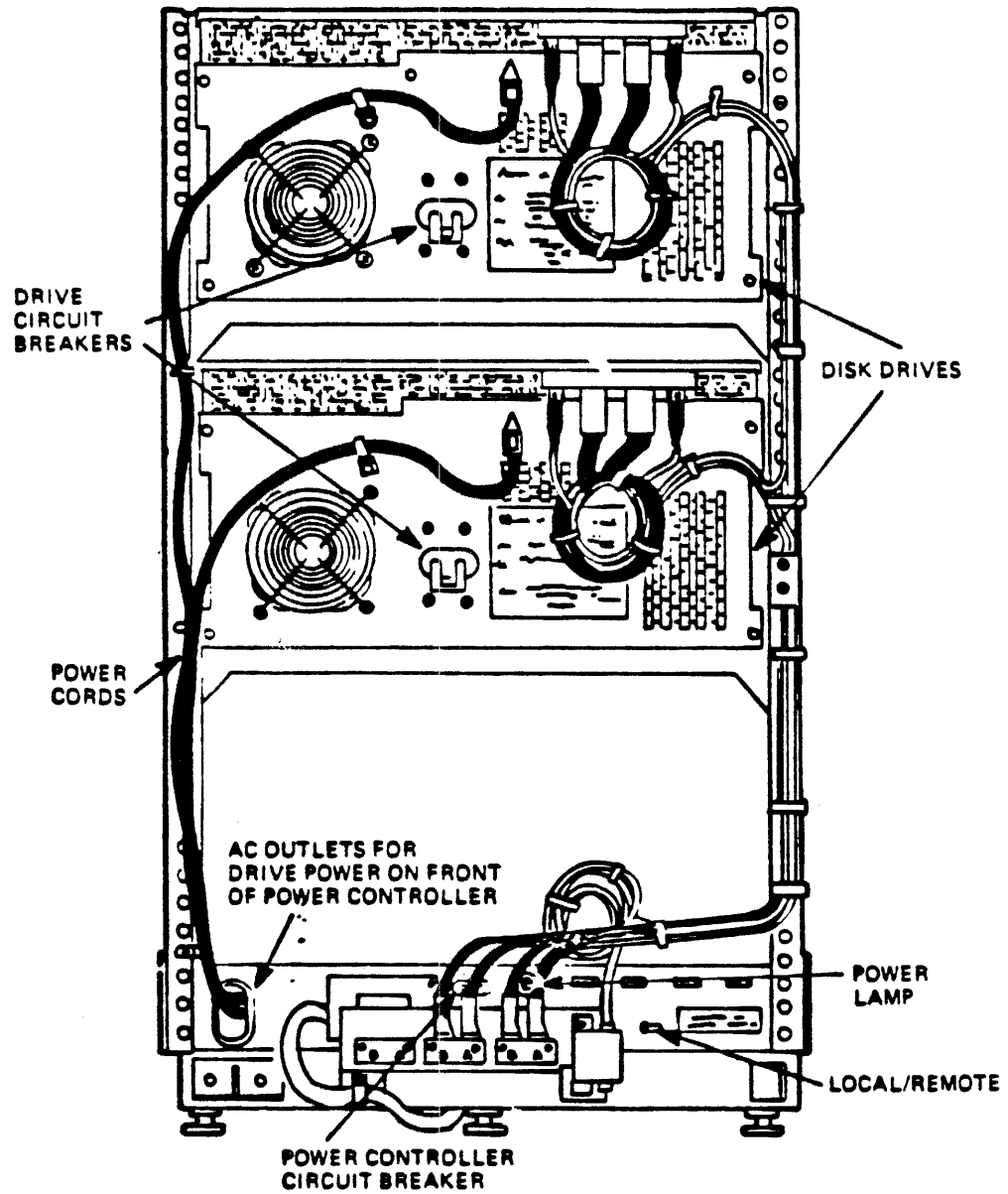
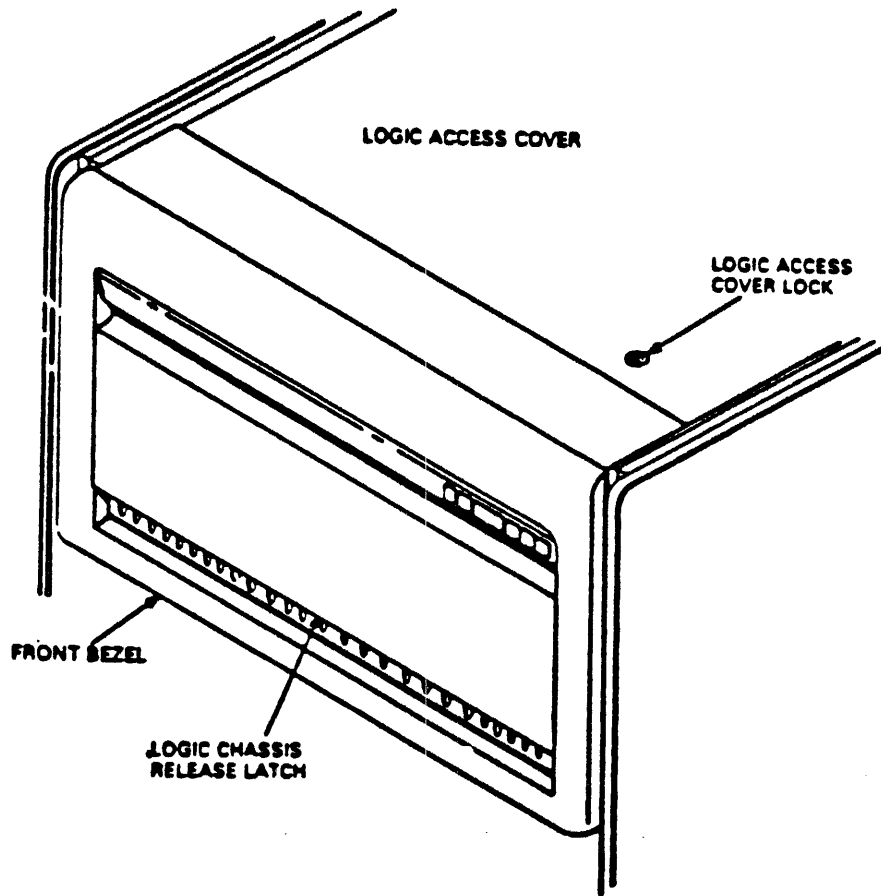

Figure 2 Review of Drive

PRELIMINARY

SUBJECT TO CHANGE WITHOUT NOTICE



C2-6728

Figure 3 Access to the Inside of the Drive

PRELIMINARY

SUBJECT TO CHANGE WITHOUT NOTICE

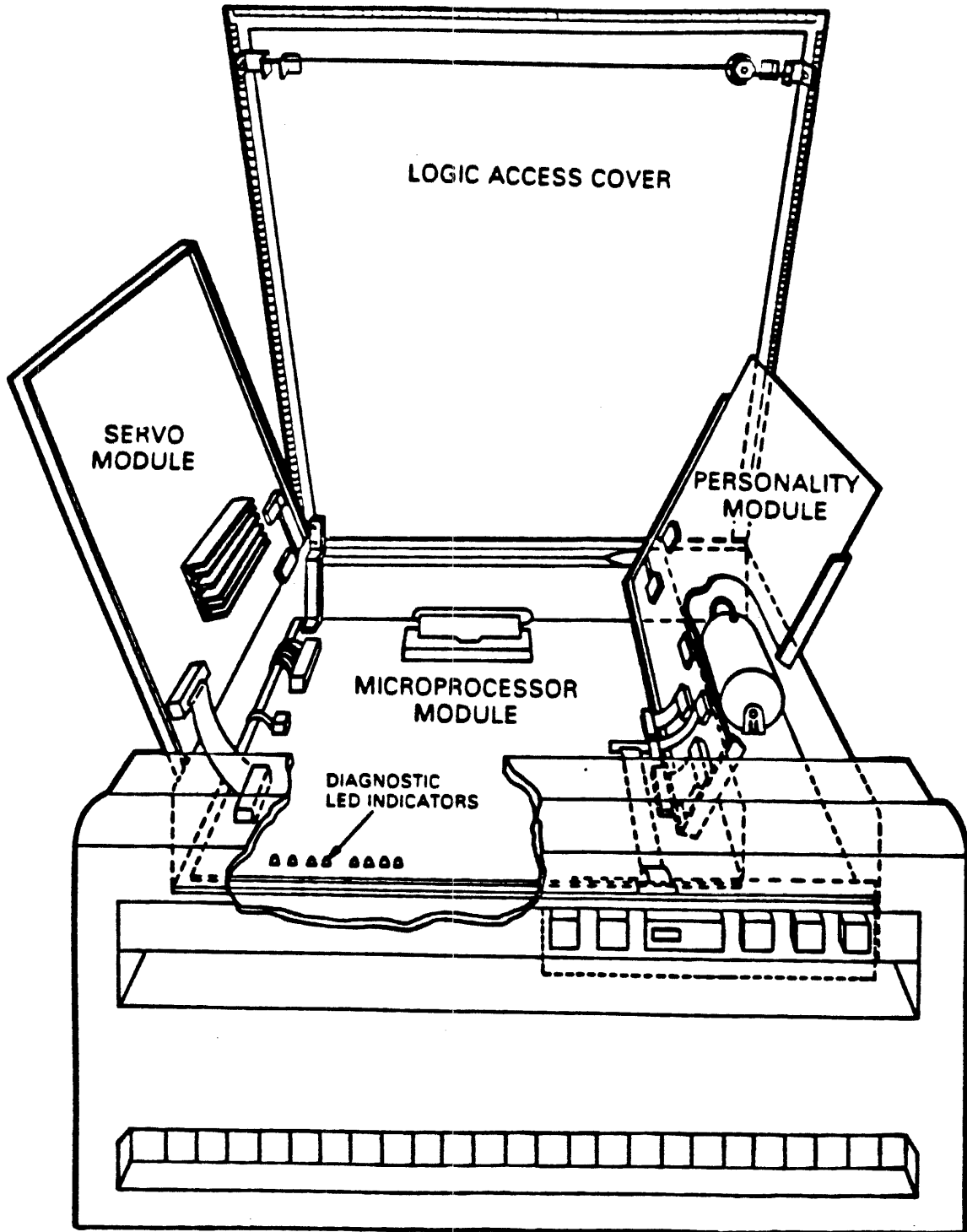
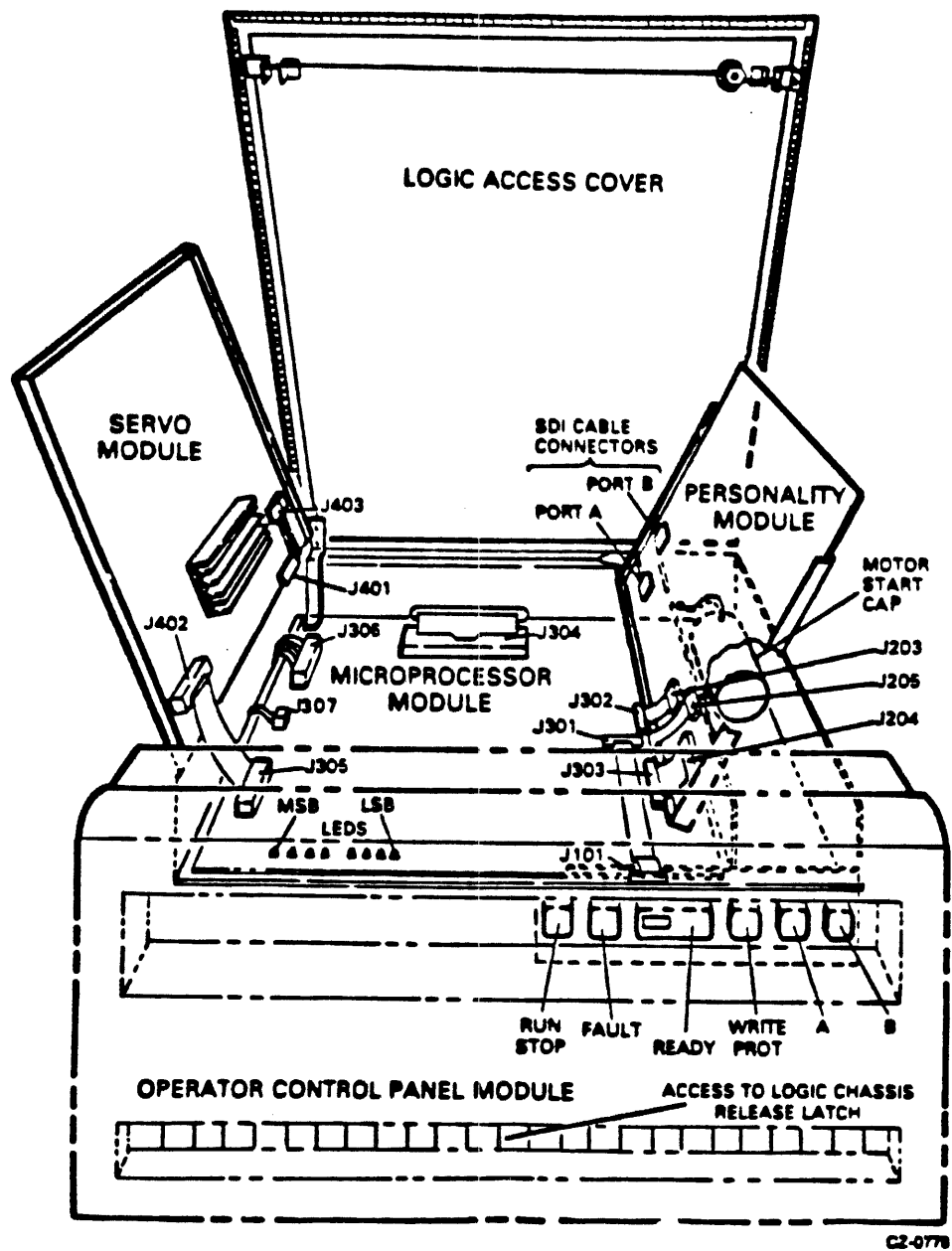

Figure 4 Upper Logic Assembly

PRELIMINARY

SUBJECT TO CHANGE WITHOUT NOTICE



C2-6776

Figure 5 Upper Logic Assembly

PRELIMINARY

SUBJECT TO CHANGE WITHOUT NOTICE

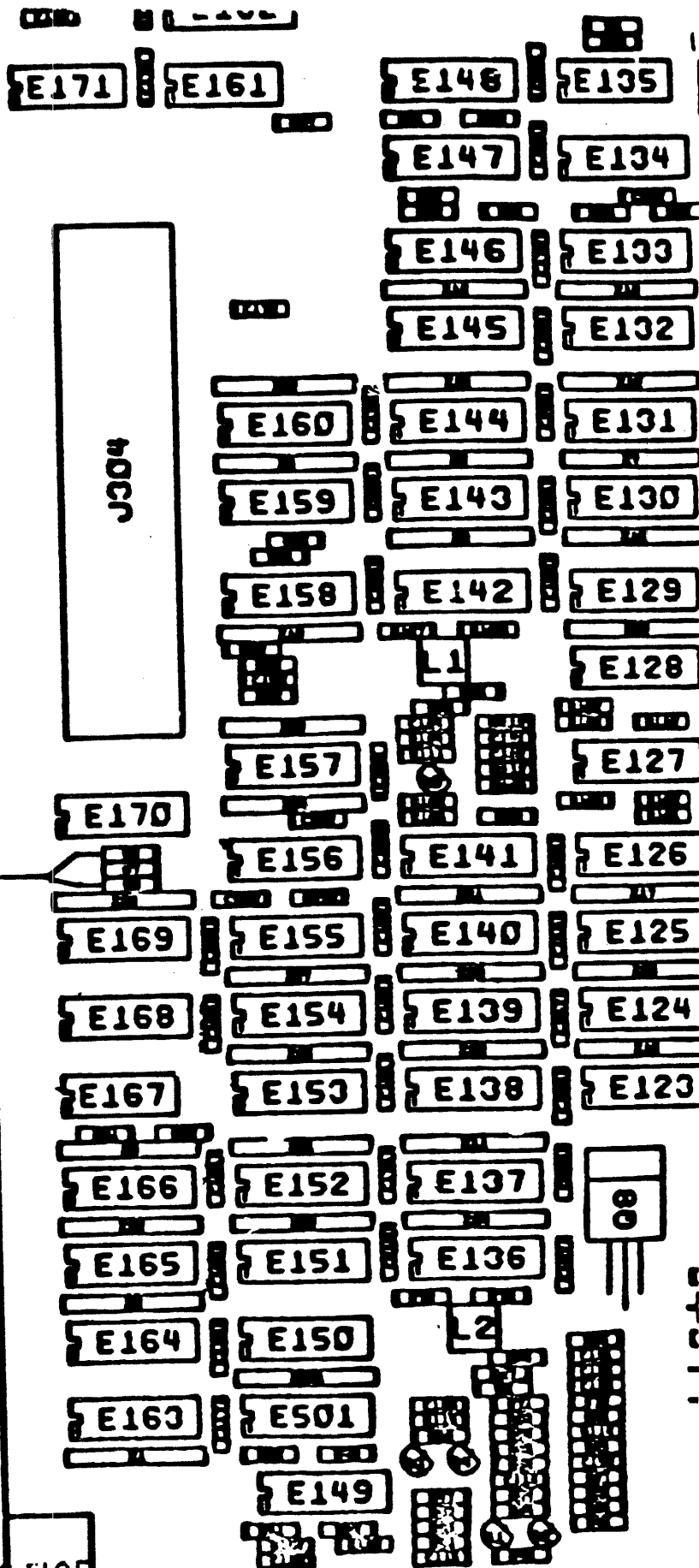
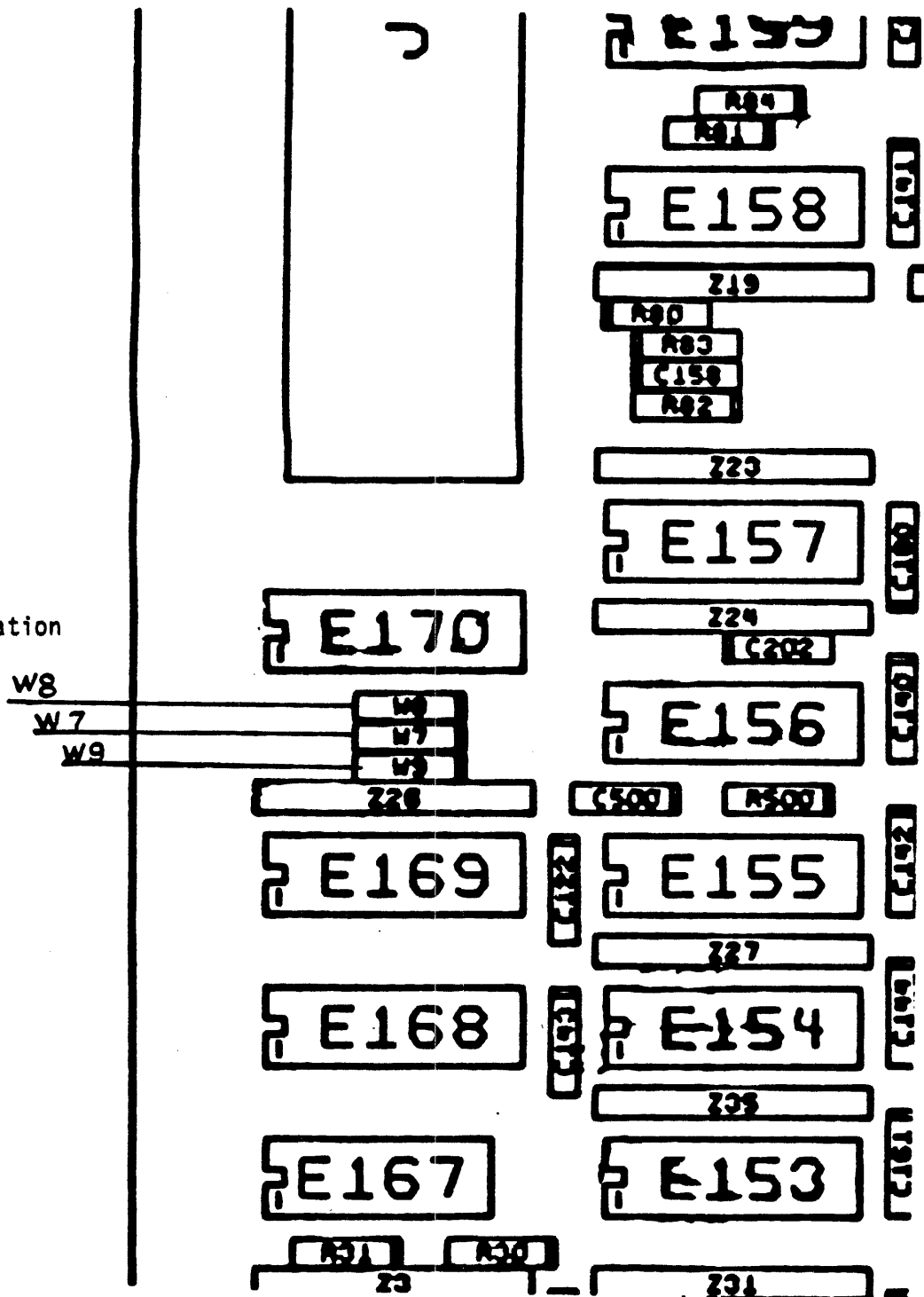

Figure 6
JUMPER LOCATIONS

PRELIMINARY

UBJECT TO CHANGE WITHOUT NOTICE

Figure 7
Jumper Location



PRELIMINARY

SUBJECT TO CHANGE WITHOUT NOTICE

Figure 8
Jumper Location

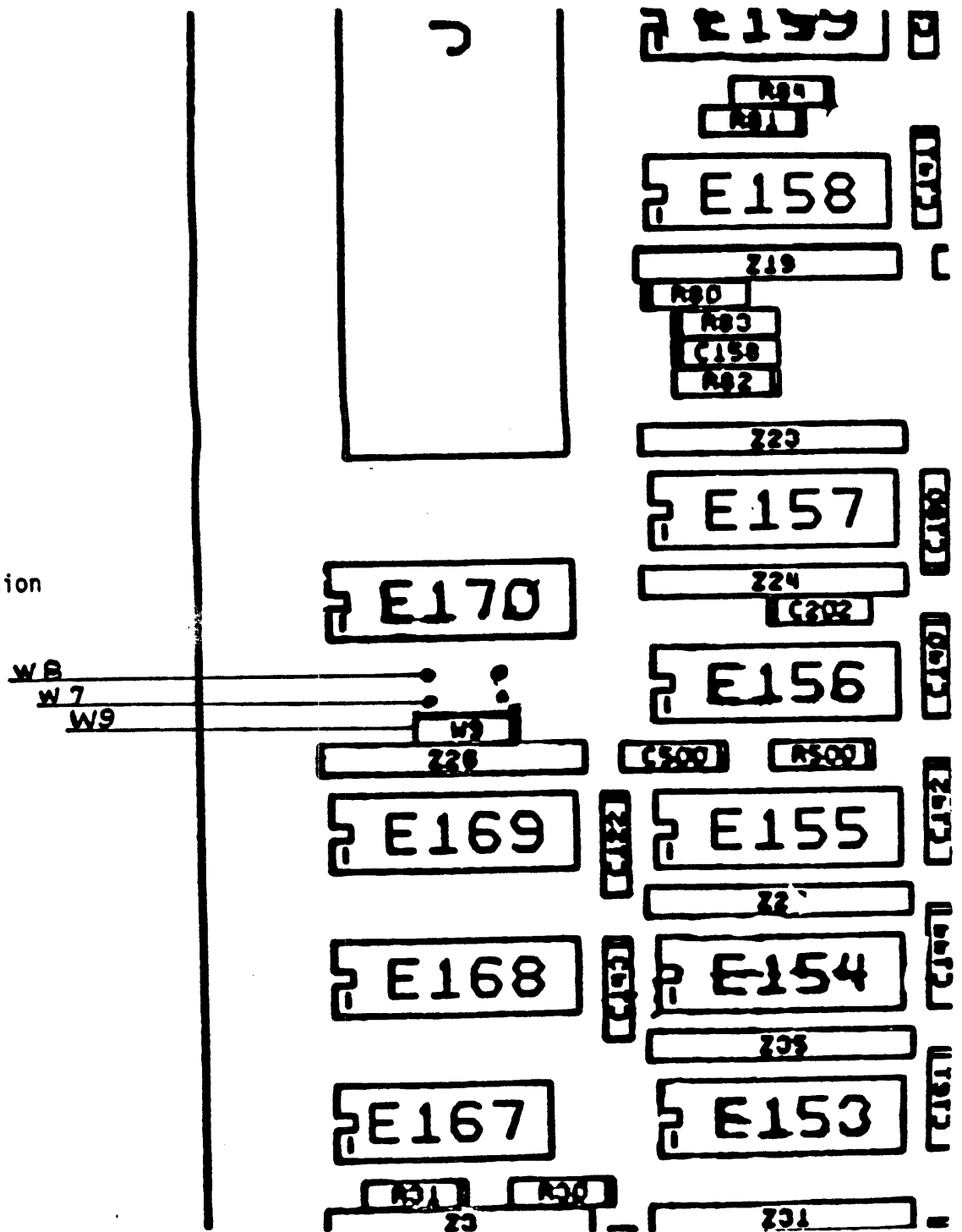

PRELIMINARY

SUBJECT TO CHANGE WITHOUT NOTICE

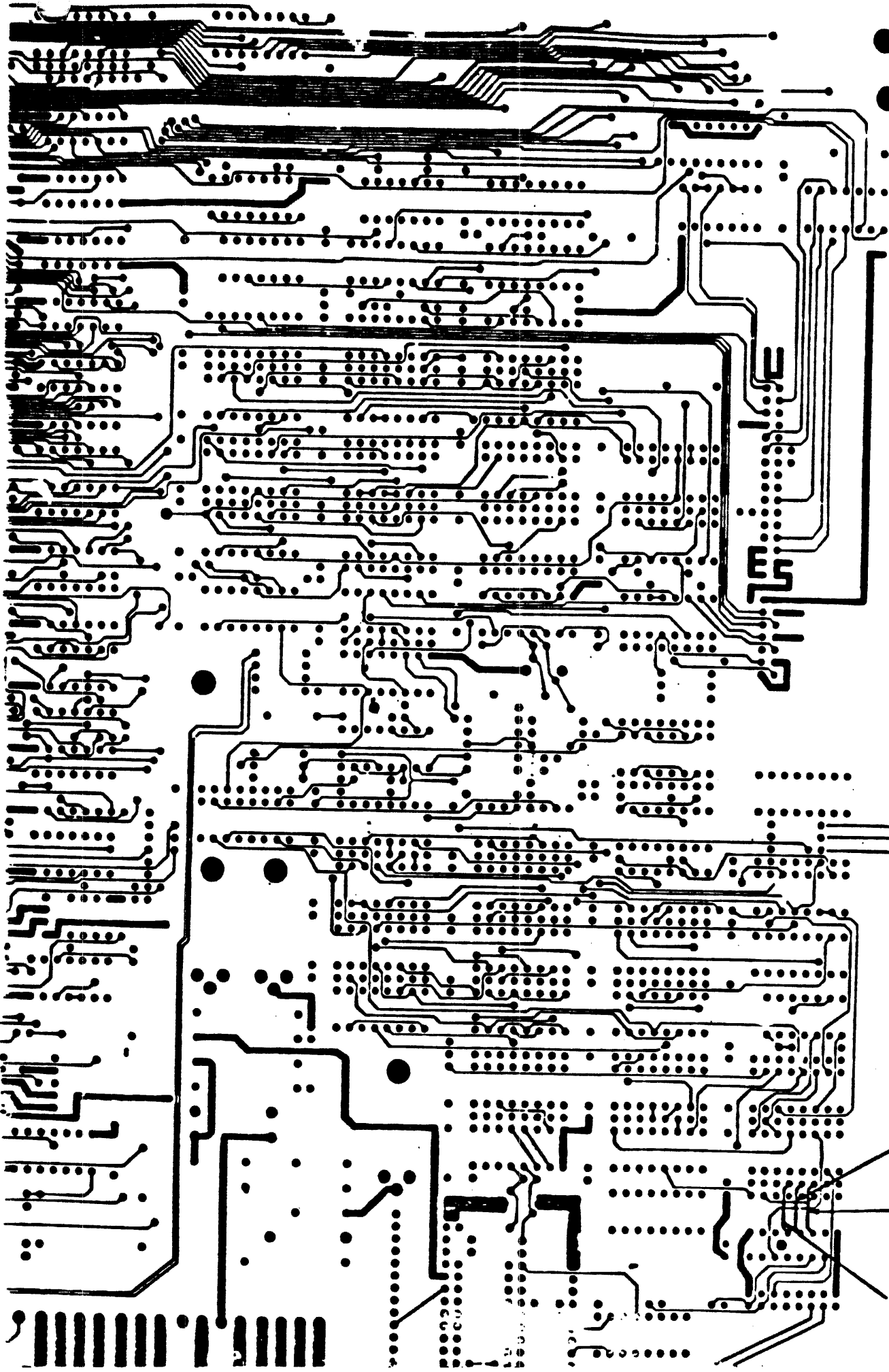

Figure 9
Rear View of
Jumper Location

W8 W7 W9

10-18
10-17
10-19

digital

Level of Urgency

Page ___
Of ___

FCO RA81X-I-014

+---+
| J |
+---+

FIELD CHANGE ORDER

Number: RA81X-I-014

Applicability: ALL RA81 DISK DRIVES

Problem/Symptom: HDA CHASSIS AND DRIVE CHASSIS ARE AT DIFFERENT GROUND REFERENCE. DATA ERRORS (ECC) NOT RELATED TO MEDIA DEFECTS.

Quick Check: GROUND STRAP ATTACHED BETWEEN HDA AND POWER SUPPLY CHASSIS GROUND STUD.

Compatibility/Prerequisite FCO:
RA81X-R-0009 AND RA81X-R-0012

Est. Time to Install:
.5

Special Tools or Test Equipment:

FCO Parts Information

Order by FCO Kit#:	Quantity:	Part Number:	Description:
EQ-01380-01	1	12-25629-01	GROUNDING STRAP
	3	90-08151-00	WASHER, EXT TOOTH
	4	90-10075-01	SCREW, TAP HEXWW
	3	90-06565-00	NUT, HEX EXT TOOTH
	3		LCKWSHR 10-32
FA-04662-01	1	90-07651-00	WASHER, LOCK
			FCO DOCUMENTATION

EQ Kit Variation System/Option Applic:

Approvals

CSSE Engineer KEITH BROWN	F.S. Product Safety	F.S. Logistics
CSSE Manager RON MILANO	F.S. Microfiche Libraries	Affected Population:
ESD&P Micropub.	<p>PRELIMINARY</p> <p>SUBJECT TO CHANGE WITHOUT NOTICE</p>	Initial Kitting:
Revision:		Hardcopy Publication:
FCO Release Date		Parts Availability:

HDA GROUND STRAP INSTALLATION

1. Request the RA81 drive from the customer.
2. Depress the "A" and the "B" port switches on the Operator Control Panel to the "OUT" position (FIGURE 1).
3. The RA81 drive must be dismounted and deselected.
4. Spin down the drive by depressing the RUN/STOP switch on the Operator Control Panel to the "OUT" position (FIGURE 1).
5. Open the back door to the cabinet.

* C A U T I O N *
* *
* BEFORE PROCEEDING, TURN OFF THE AC CIRCUIT BREAKER *
* AT THE REAR OF THE DRIVE AND DISCONNECT THE MAIN *
* AC POWER CORD FROM THE POWER SUPPLY ON THE REAR OF *
* THE DRIVE (FIGURE 2). *
* *

6. If the drive is fixed mounted (top drive), proceed to rework step 11.
7. Pull out the cabinet stabilizer bar (FIGURE 3).

* C A U T I O N *
* *
* NEVER SLIDE A DRIVE OUT OF THE CABINET WITHOUT *
* EXTENDING THE CABINET STABILIZER BAR. *
* *

8. Remove the screw holding the back of the disk drive to the electrostatic discharge bracket (FIGURE 4).
9. Slowly pull the drive out on it's slides until it locks into place.
10. Push up on the slide lock arm "A" to further extend the drive all the way out (FIGURE 5).
11. Raise the drive logic chassis by pushing the release latch with a standard screwdriver (FIGURE 6).
12. Attach E.S.D. wrist strap to chassis ground stud (FIGURE 7).

PERMANENT

SUBJECT TO CHANGE WITHOUT NOTICE

13. Remove all four (4) of the Read/Write Module (54-15253) hold down screws. Save the shorter screws and return to stock (FIGURE 8).
14. Lift the rear portion of the Read/Write module up to expose the HDA mounting standoff.
15. Place one Star Washer (90-08151-00) under the left and right mounting standoff (FIGURE 8).
16. Lay the Read/Write back in place, and attach the two front hold down screws using the Longer Screws (90-10075-01) supplied in the F.C.O. EQ Kit.
17. Insert the Longer Screw through one end of the HDA Ground Strap (12-25629-01) (FIGURE 8).
18. Place one Star Washer (90-08151-00) on top of the left rear Read/Write module grounding pad (FIGURE 8).
19. Attach Ground Strap, Longer Screw, and Star Washer to the left rear Read/Write module hold down. Insure that the lower Star Washer is still in place (FIGURE 8).
20. Attach the other end of the Ground Strap to the Power Supply ground stud using the Kept Nut and Star Washer supplied in the EQ Kit (SEE DETAIL A and B of FIGURE 7).
21. Close the logic chassis, DO NOT SLAM SHUT - HDA DAMAGE MAY OCCUR.
22. The Hardware Revision level switches are to be changed to seven (7). Remove the front bezel by removing the upper and lower mounting screws from each side of the drive (FIGURE 10).
23. Remove the Operator Control Panel from the Bezel (FIGURE 11) and change the switches to reflect a hexadecimal seven (7) (FIGURE 9).
24. Replace the front bezel cover.
26. If this is a fixed mount drive, proceed to step 28.

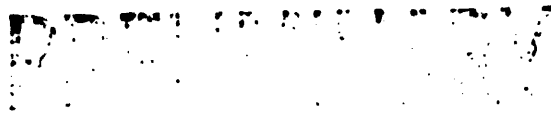

27. Push in on slide arm "B" and slowly slide the drive back into the cabinet (FIGURE 5).
28. Reinstall the screw holding the back of the drive to the electrostatic discharge bracket (FIGURE 4).

```

*****
*                                     *
*                   C A U T I O N     *
*                                     *
*   THE SCREW HOLDING THE BACK OF THE DRIVE TO THE   *
*   ELECTROSTATIC DISCHARGE BRACKET MUST BE INSTALLED *
*                                     *
*****

```

29. Reconnect the AC power cord at the rear of drive, to the AC receptacle (FIGURE 2).
30. Turn the AC Circuit Breaker, at the rear of the drive, to the "ON" position (FIGURE 2).
31. Spin up the drive by pressing the RUN/STOP switch (FIGURE 1).
32. After the drive has spun up and a ready light is "ON", press the "A" and/or "B" port switches on the Operator Control Panel to the "IN" position (FIGURE 1).
33. Run at least one (1) pass of RA81 drive diagnostics.

VAX	32 BIT	UDA50, EVRLA or EVRLG HSC50/ILEXER
PDP-11	16 BIT	UDA50,CZUDC or CZUDI
DEC 10/20	36 BIT	HSC50/ILEXER

34. Return the RA81 drive to the customer for software initialization.
35. Enter the FCO activity in the Site Management Guide and complete the LARS form for FCO reporting.

PRELIMINARY

SUBJECT TO CHANGE WITHOUT NOTICE

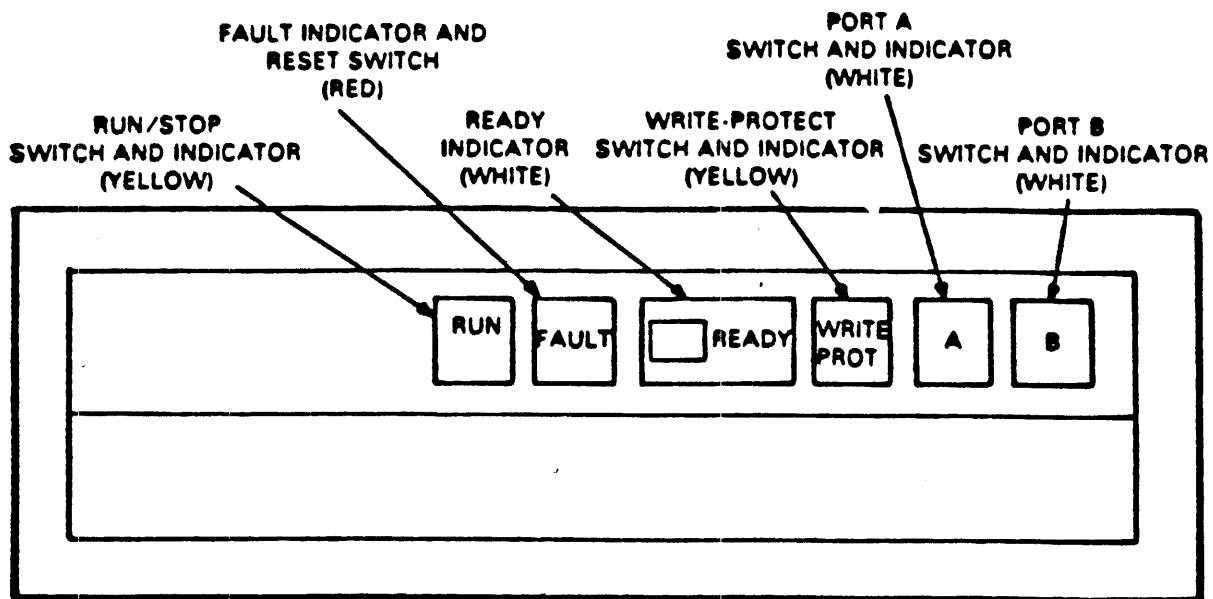

Figure 1 Front-Panel Controls and Indicators

PRELIMINARY

SUBJECT TO CHANGE WITHOUT NOTICE

PRELIMINARY

SUBJECT TO CHANGE WITHOUT NOTICE

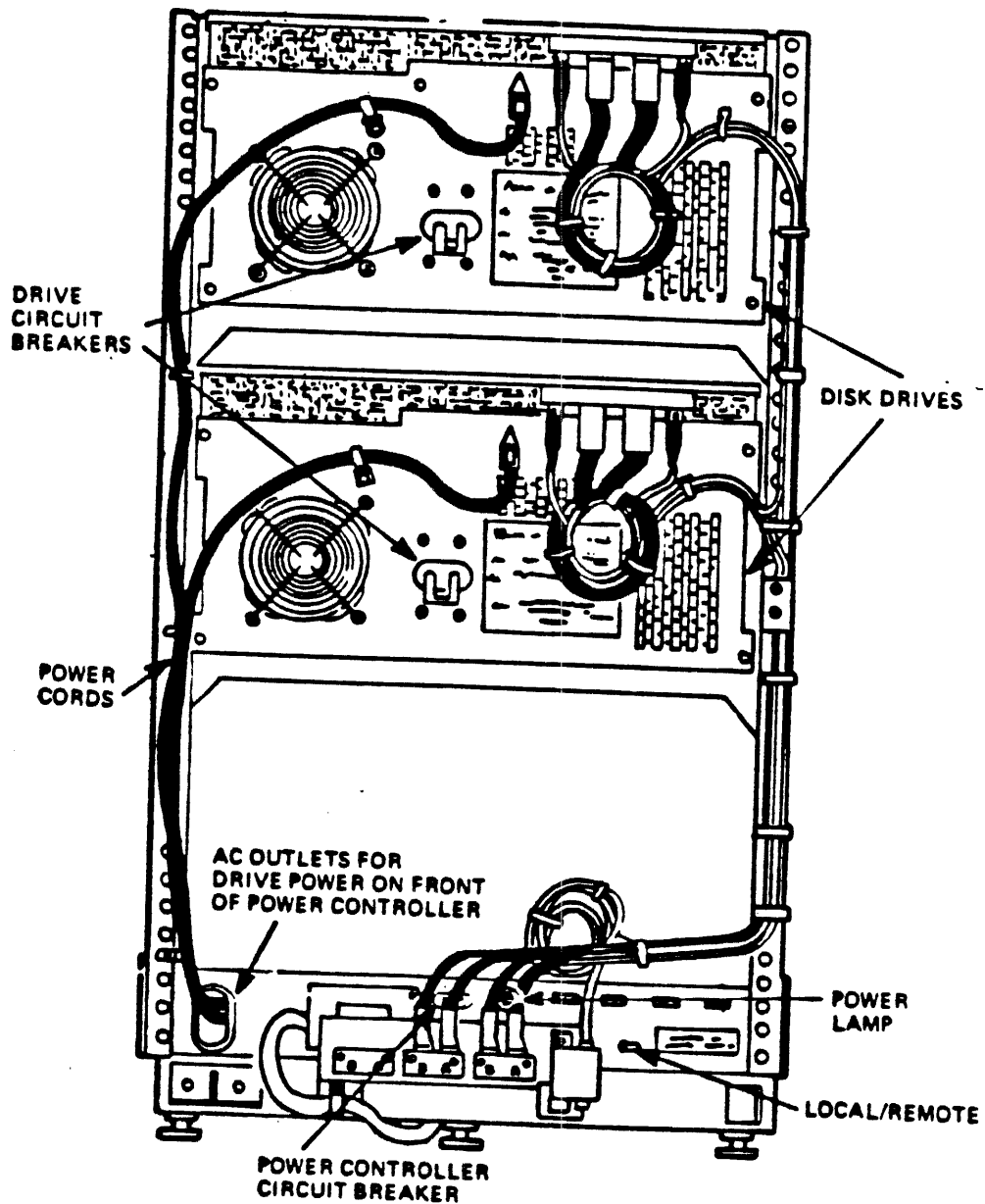

Figure 2 BACK OF AN RAB1 DRIVE

PRELIMINARY

SUBJECT TO CHANGE WITHOUT NOTICE

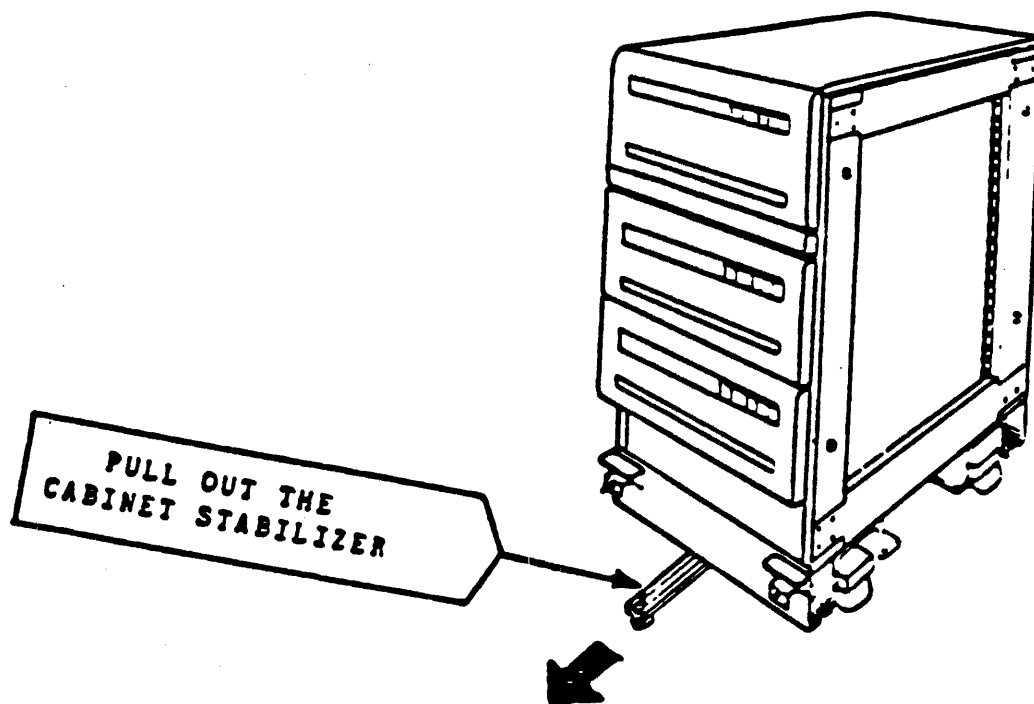

FIGURE 3
STABILIZER BAR

PRELIMINARY

SUBJECT TO CHANGE WITHOUT NOTICE

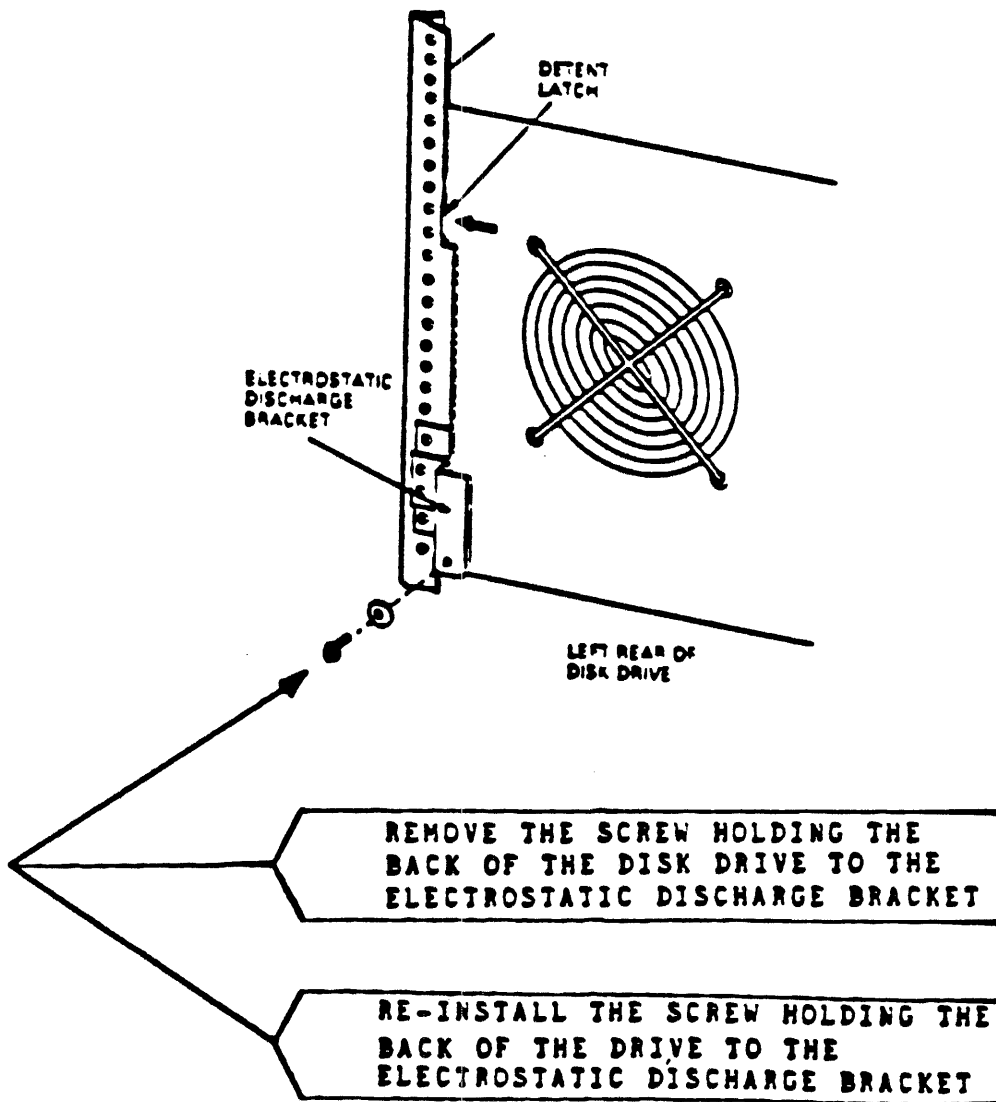

FIGURE 4
ELECTRO DISCHARGE BRACKET

PRELIMINARY

SUBJECT TO CHANGE WITHOUT NOTICE

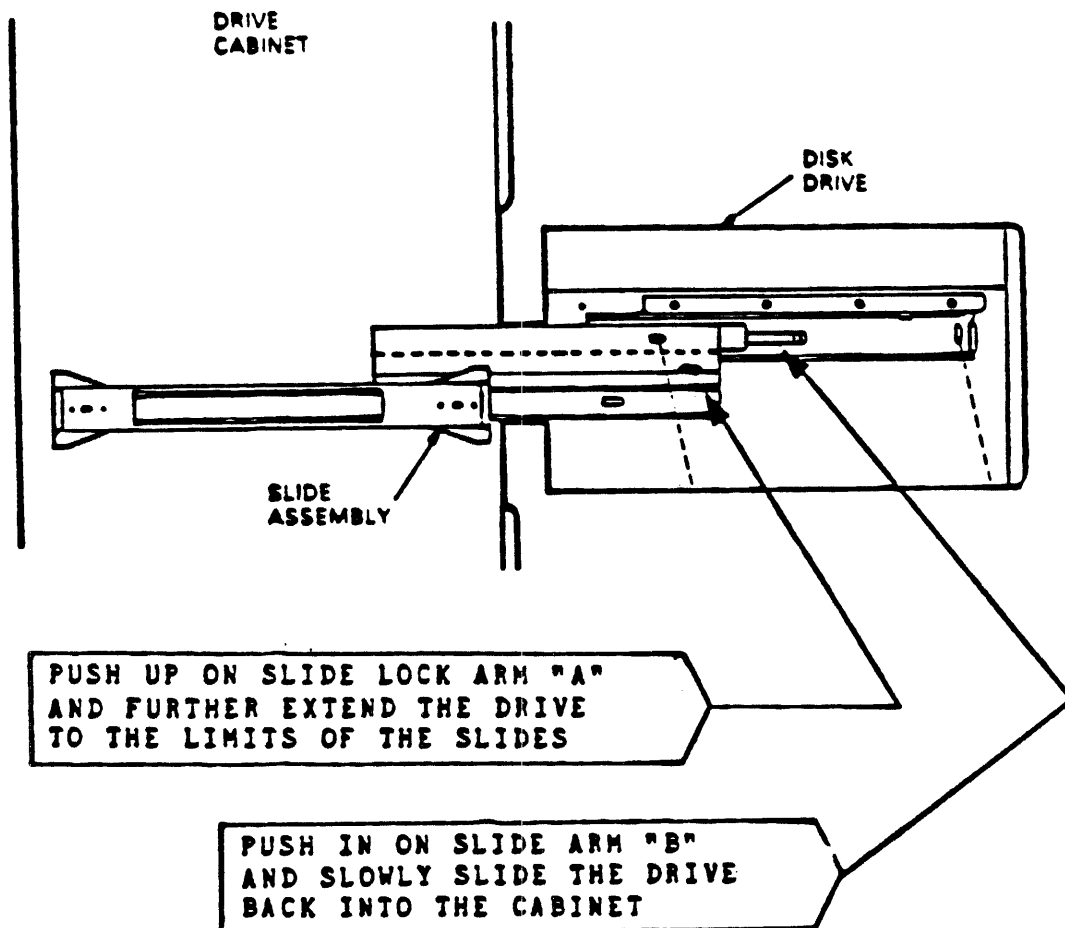

FIGURE 5

DRIVE SLIDE ARMS

PRELIMINARY

SUBJECT TO CHANGE WITHOUT NOTICE

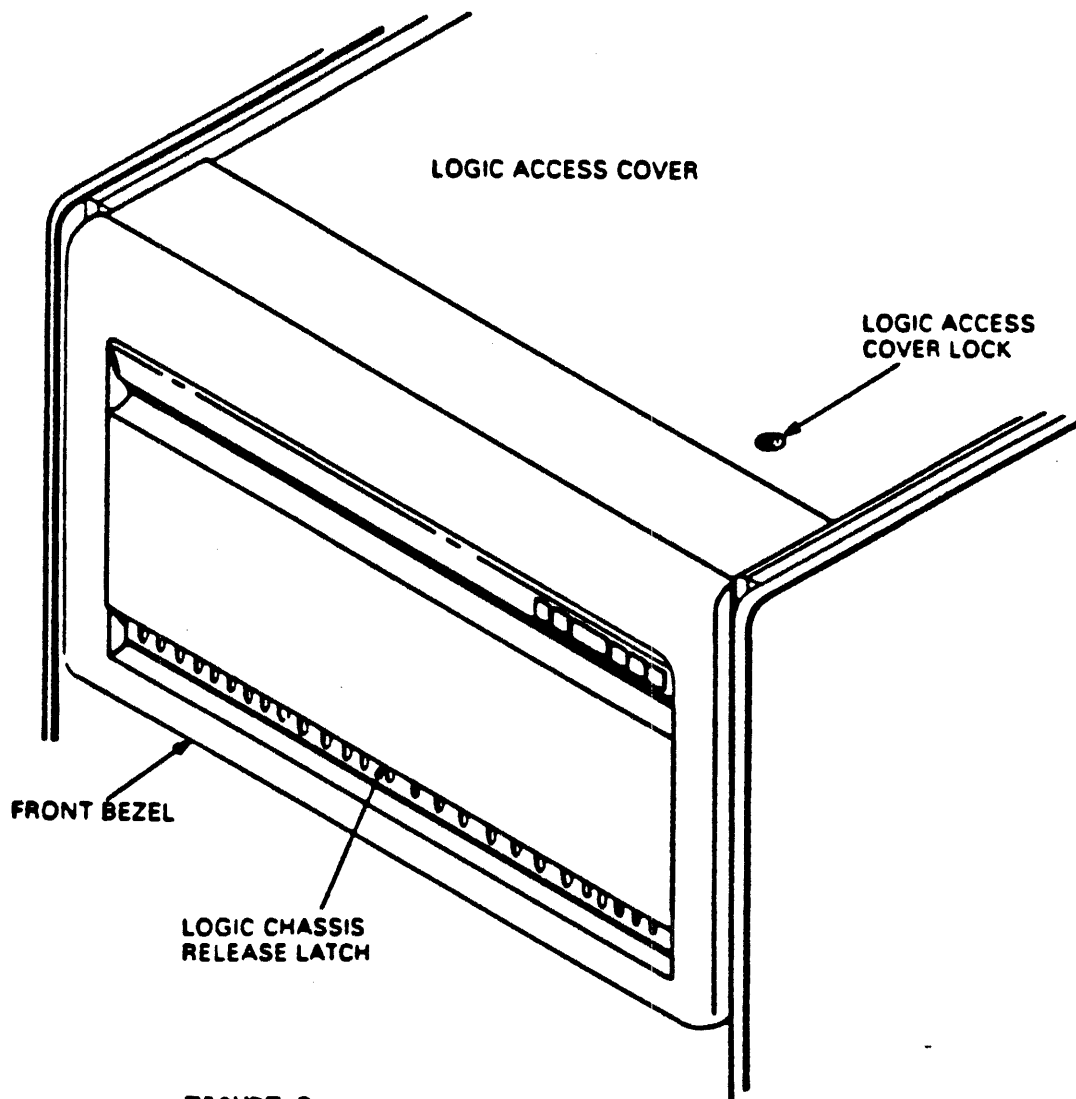

FIGURE 6

LOGIC CHASSIS RELEASE LATCH

PRELIMINARY

SUBJECT TO CHANGE WITHOUT NOTICE

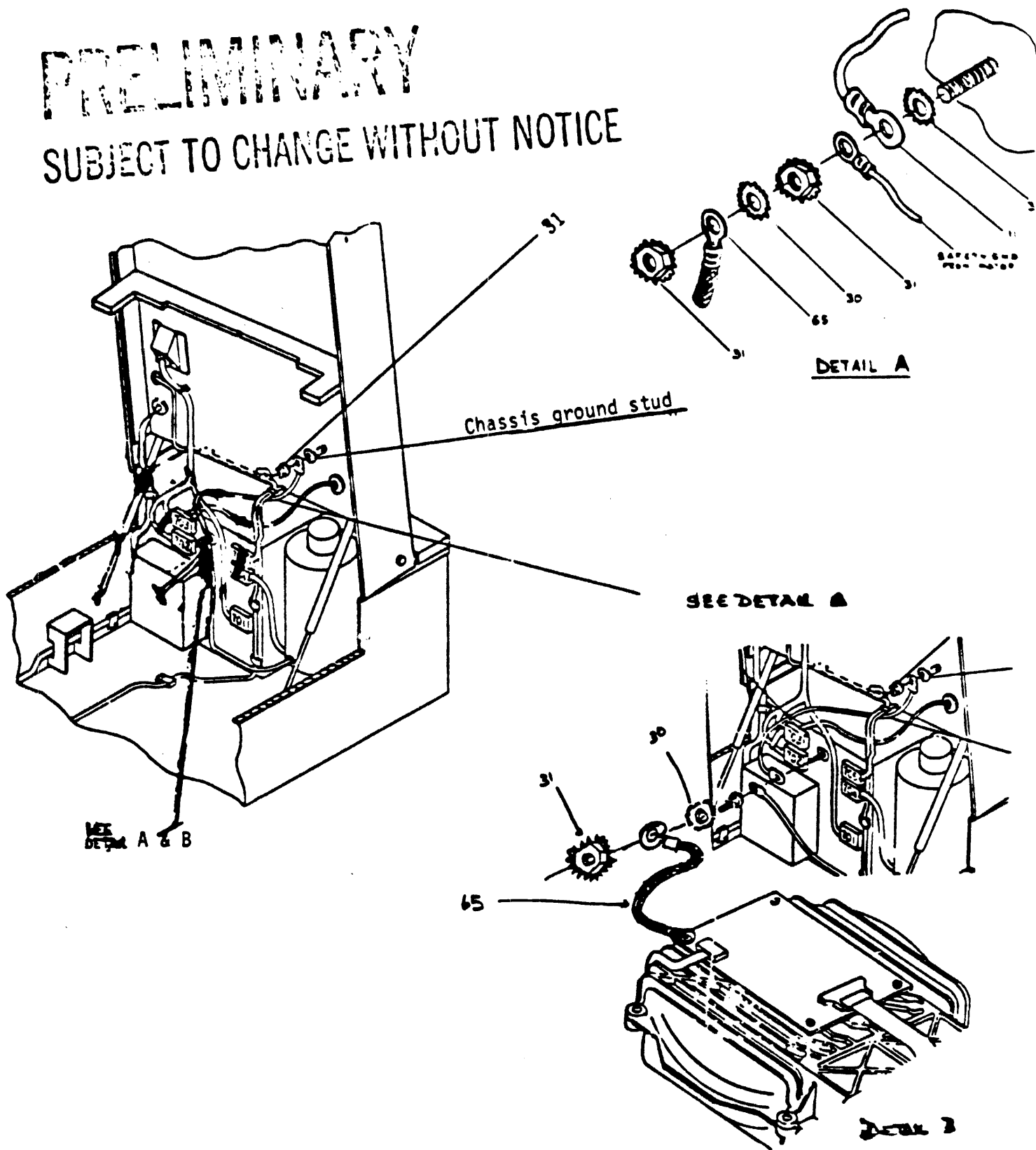

FIGURE 7

PRELIMINARY

SUBJECT TO CHANGE WITHOUT NOTICE

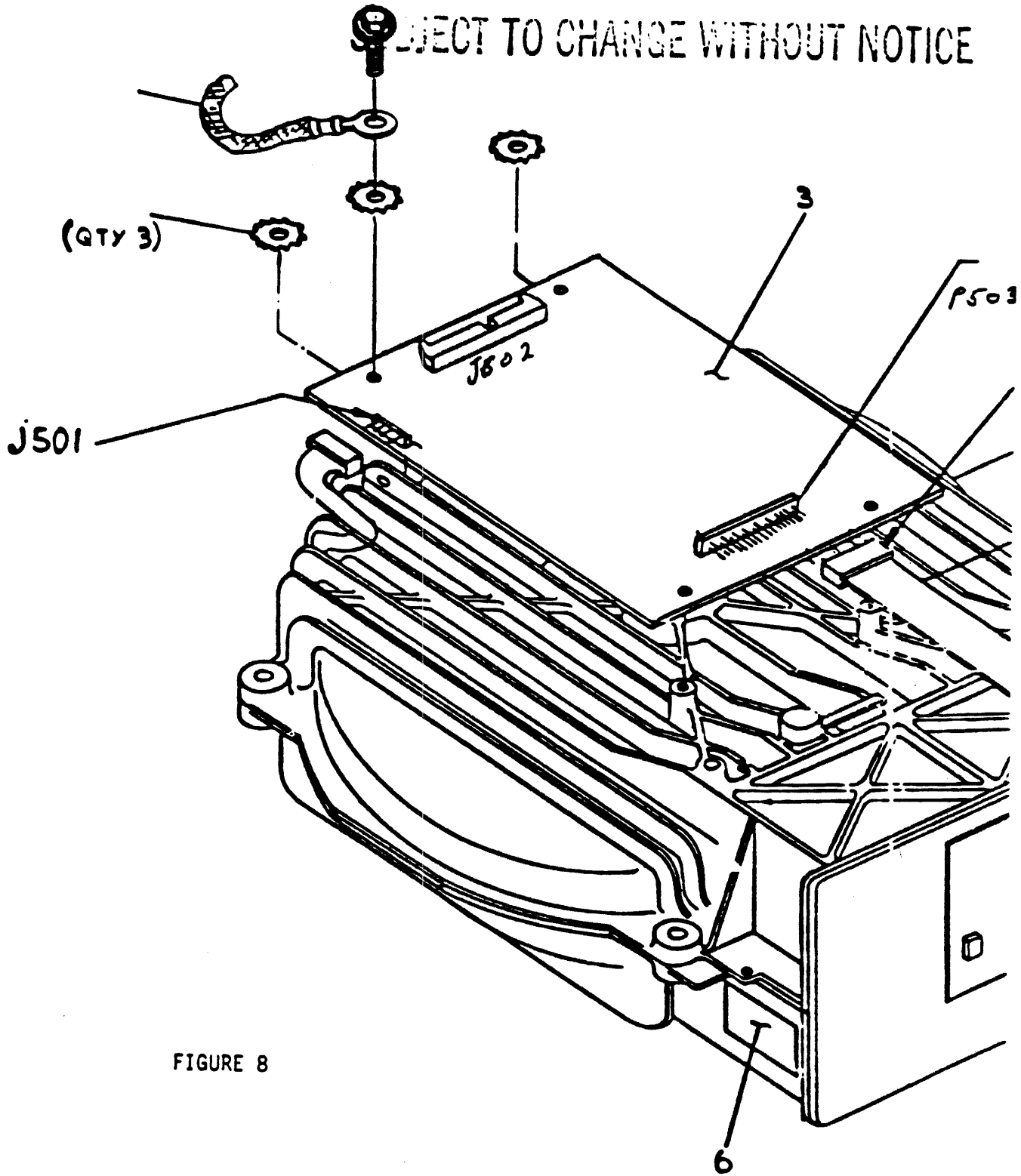

FIGURE 8

PRELIMINARY

SUBJECT TO CHANGE WITHOUT NOTICE

Set the DIP SWITCHES for the Hardware Revision Level on the Operator Control Panel (54-14927) to the indicated positions:

- 20 = OFF
- 21 = OFF
- 22 = OFF
- 23 = ON

This will indicate RAB1 HARDWARE REVISION '7'

NOTE: ON = Binary 0
OFF = Binary 1

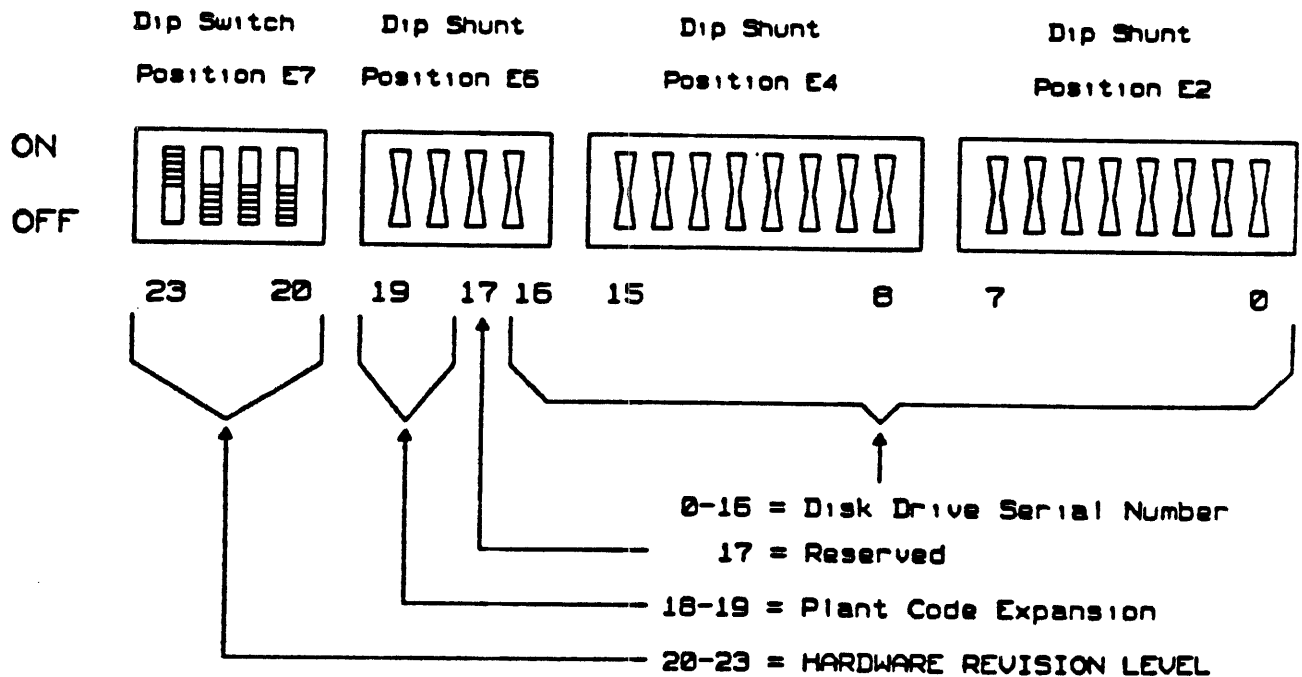

HARDWARE REVISION LEVEL SWITCHES FIGURE 9

P... ..

SUBJECT TO CHANGE WITHOUT NOTICE

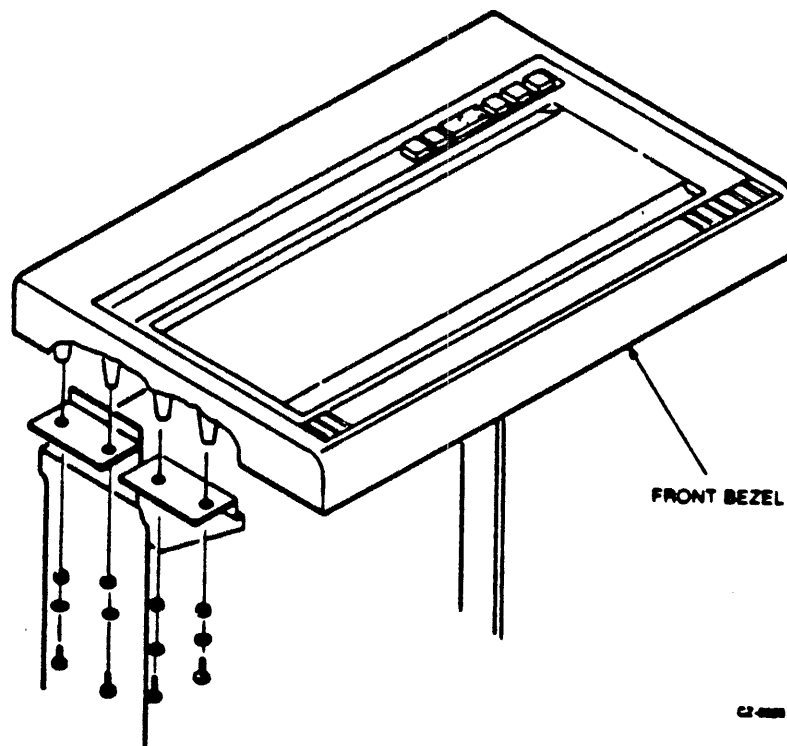

FRONT BEZEL REMOVAL FIGURE 10

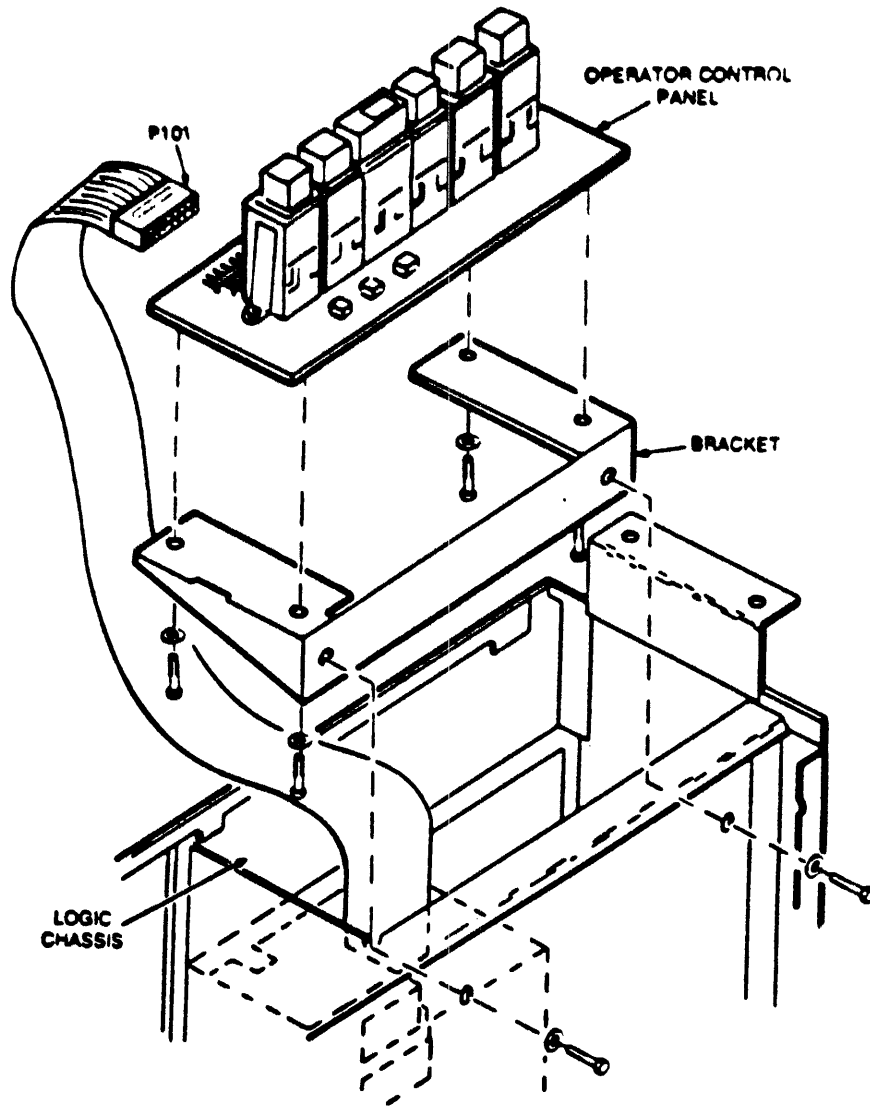

CS-487

OPERATOR CONTROL PANEL REMOVAL FIGURE 11

PRELIMINARY

SUBJECT TO CHANGE WITHOUT NOTICE